

SUNLIGHT  
80 F  
95 F  
80 FR  
95 FR

20.04.2026\_rev.01



KE



# SUNLIGHT 80 F

# KE



↔ 100 ↻ 100



↔ 600 ↻ 450

Sunlight is a structure with a laminated glass roof that is 10 (5+5+1,52 mm) or 12 mm (6+6+1,52 mm) thick and composed of step glass crossbars (max 80/95 cm. standard or reinforced inside) made of aluminum. It is available in two different finishes - transparent or white. Sunlight is available free-standing or wall-mounted configuration and is easily adapted to a variety of spaces with a simple and clean design. Dimmable LED lighting is available to extend enjoyment of Sunlight to evening hours. Sunlight can be integrated with multiple types of closures, including Line Glass sliding windows, Vertika Sunlight and a solar shading system above and below the roof (Roof Tens). Marked structural components according to EN 1090-1 in execution class ex C2 as per EU regulation 305-2011.

## OPTIONAL

VERTIKA

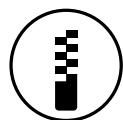

GLASS DOORS



LIGHT



# TECHNICAL INFORMATION

## General technical plan

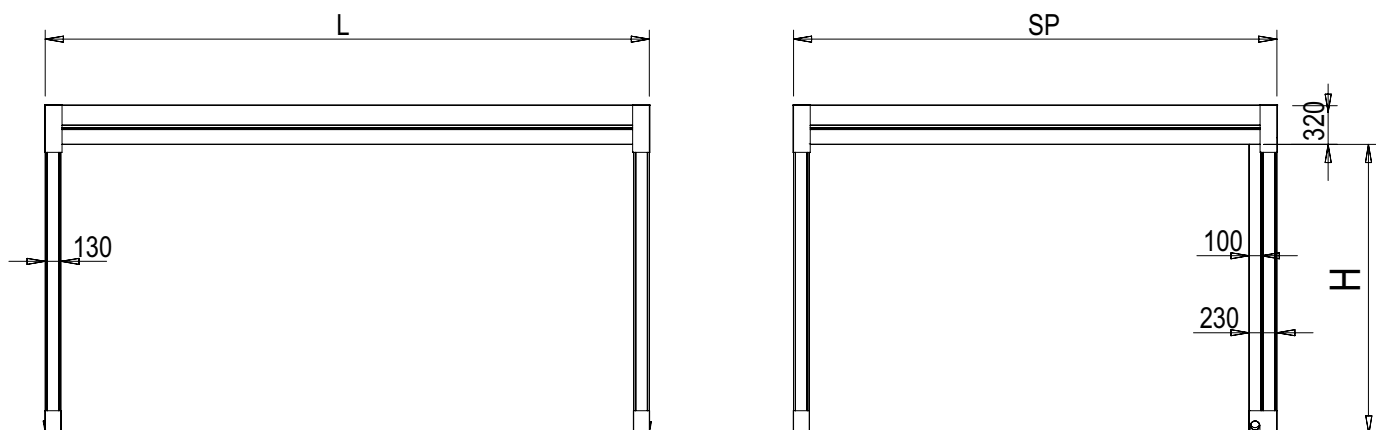

## Girder section

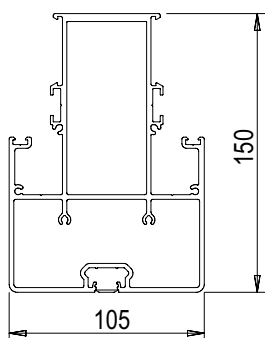

Standard glass door beam

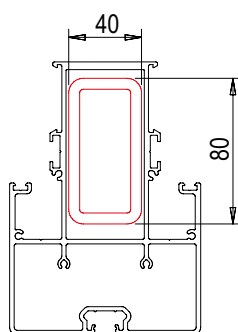

Reinforced glass beam

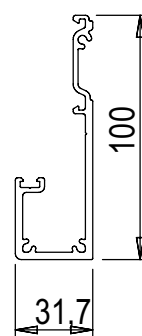

Glass door side beam

# TECHNICAL INFORMATION

## Ground connection

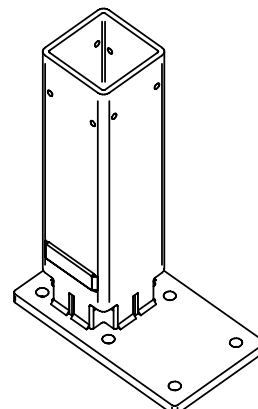
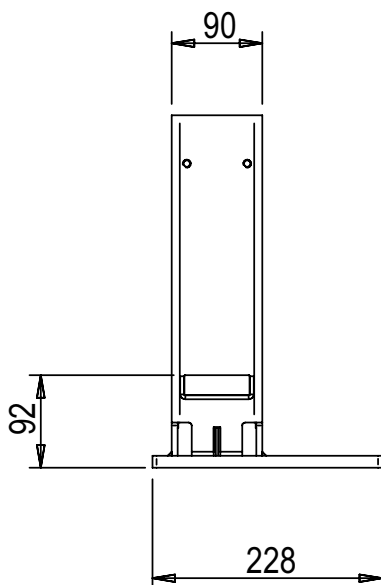
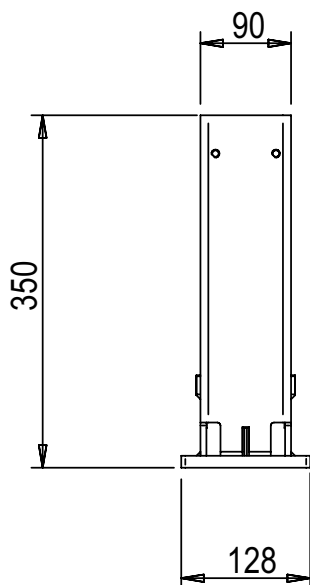

STANDARD - Column foot with drain

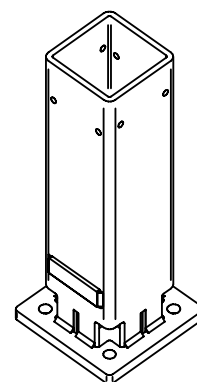
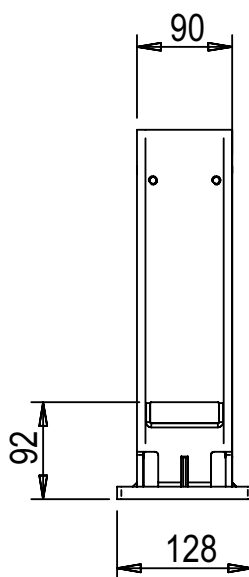
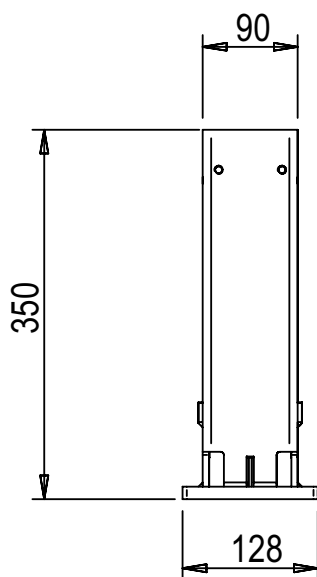

STANDARD - Column foot without drain

# TECHNICAL INFORMATION

## Ground connection

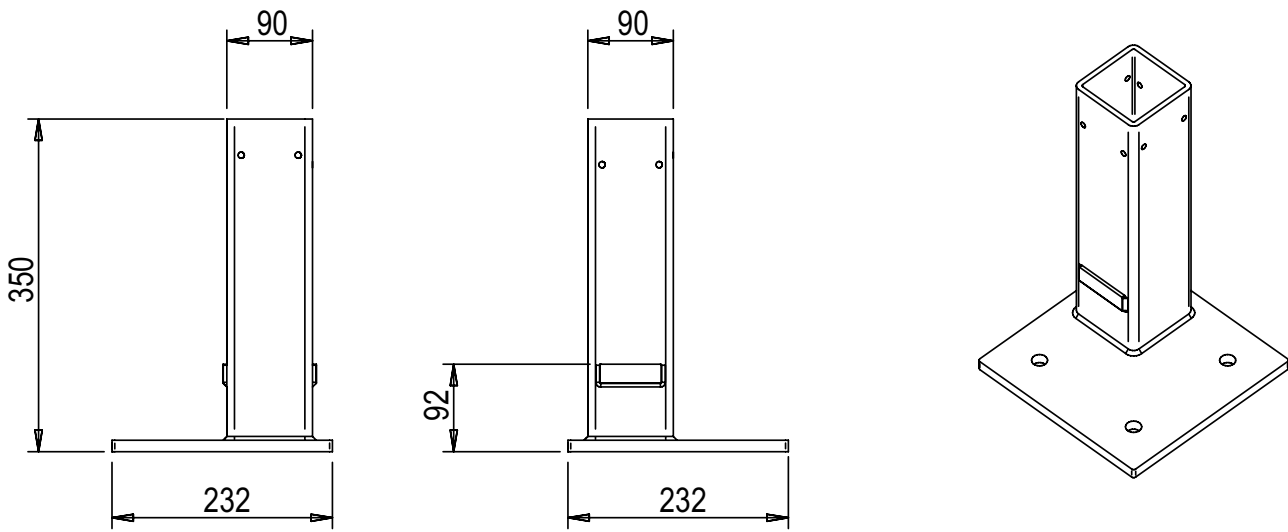

OPTIONAL - Foot with external base

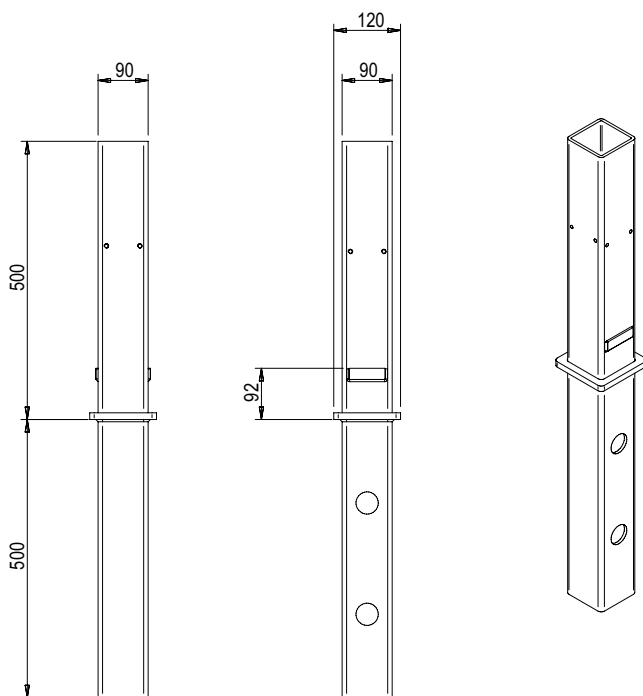

OPTIONAL - Foot for underground fixing

### MAX WEIGHT SUNLIGHT 80 F - 4 Pillars (Kg/m<sup>2</sup>)

		Width (cm)							
Projection (cm)		250	300	350	400	450	500	550	600
	250	611	673	716	615	655	554	449	349
	300	409	452	482	412	440	388	366	282
	350	287	319	341	289	310	272	307	235
	400	188	211	227	190	204	178	225	199
	450	117	133	144	119	129	110	143	127
N° Glass		3	4	5	5	6	6	8	8

### MAX WEIGHT SUNLIGHT 95 F - 4 Pillars (Kg/m<sup>2</sup>)

		Width (cm)							
Projection (cm)		250	300	350	400	450	500	550	600
	250	611	492	563	482	538	476	449	349
	300	409	327	376	319	358	315	347	282
	350	287	227	263	221	250	218	242	216
	400	188	146	171	142	162	140	156	139
	450	117	87	105	85	99	83	95	82
N° Glass		3	3	4	4	5	5	6	6

### MAX WEIGHT SUNLIGHT 80 FR - 4 Pillars (Kg/m<sup>2</sup>)

		Width (cm)							
Projection (cm)		250	300	350	400	450	500	550	600
	250	1046	1149	1183	894	696	554	449	349
	300	711	783	833	716	571	453	366	282
	350	509	562	599	513	483	381	307	235
	400	346	383	409	348	372	327	262	199
	450	228	254	272	230	247	216	227	171
N° Glass		3	4	5	5	6	6	8	8

### MAX WEIGHT SUNLIGHT 95 FR - 4 Pillars (Kg/m<sup>2</sup>)

		Width (cm)							
Projection (cm)		250	300	350	400	450	500	550	600
	250	1046	850	967	833	696	554	449	349
	300	711	575	656	563	571	453	366	282
	350	509	409	469	400	447	381	307	235
	400	346	275	317	269	302	265	262	199
	450	228	178	208	174	197	171	190	170
N° Glass		3	3	4	4	5	6	6	6

# PHOTOVOLTAIC GLASS

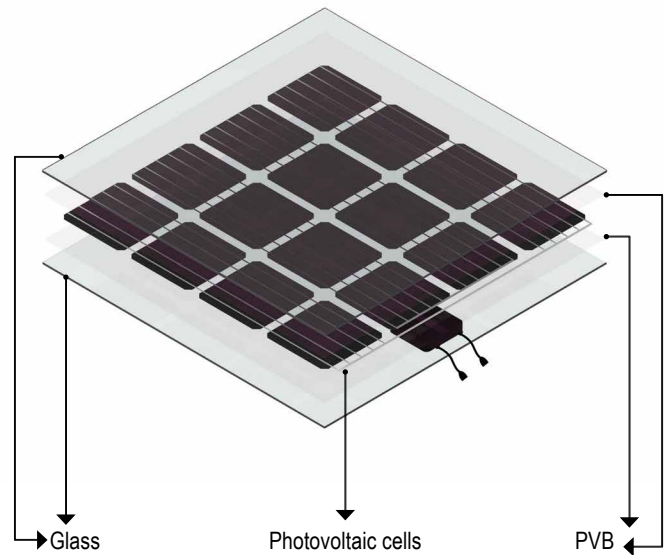

Sunlight, thanks to its versatility, offers an innovative solution for sustainable energy production by integrating laminated photovoltaic glass into the roof. Sunlight's photovoltaic cells are strategically arranged in a grid pattern, making maximum use of the available surface area. In a configuration size of 6x4.5 meters, Sunlight is capable of generating a remarkable power output of 1.4 kW.

**Photovoltaic Glass Absorption Data (Watts)**

	300 3 glass	350 4 glass	400 4 glass	450 5 glass	500 5 glass	550 6 glass	600 6 glass	650 8 glass	700 8 glass	750 8 glass	800 8 glass	850 10 glass
250	600	720	720	900	900	1080	1080	1440	1440	1440	1440	1800
300	660	880	880	1100	1100	1320	1320	1760	1760	1760	1760	2200
350	720	960	960	1200	1200	1440	1440	1920	1920	1920	1920	2400
400	720	960	960	1200	1200	1440	1440	1920	1920	1920	1920	2400
450	720	960	960	1200	1200	1440	1440	1920	1920	1920	1920	2400

	900 10 glass	950 10 glass	1000 12 glass	1050 12 glass	1100 12 glass	1150 12 glass	1200 14 glass
250	1800	1800	2160	2160	2160	2160	2520
300	2200	2200	2640	2640	2640	2640	3080
350	2400	2400	2880	2880	2880	2880	3360
400	2400	2400	2880	2880	2880	2880	3360
450	2400	2400	2880	2880	2880	2880	3360

Maximum power output may vary depending on: orientation of the structure, geographical location of installation, presence of any shading elements, cleanliness of the glass, maintenance, and temperatur

# ROOF TENS

---

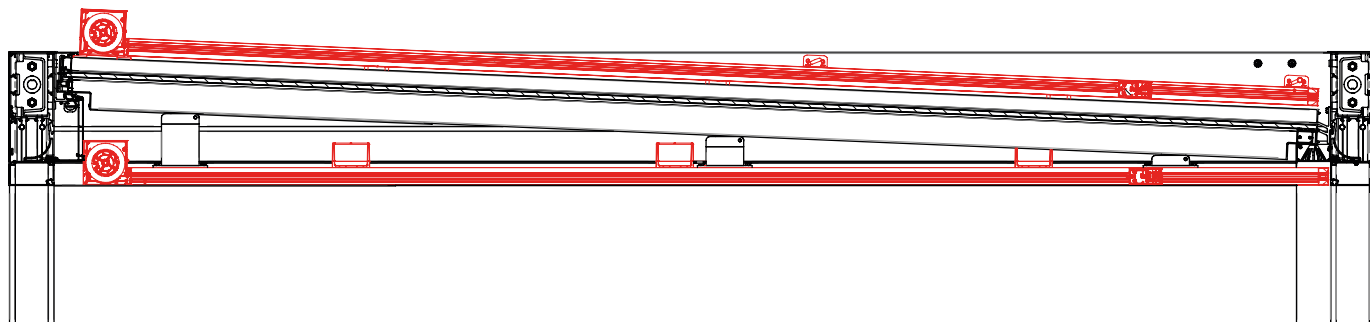

↔ 100 ↻ 50



↔ 500 ↻ 500

---

Awning with 130 cassette available in "Square" version only, with ZIP guide system.

Equipped with a spring-loaded canvas tensioning system.

It can be installed above and/or below the roof.

With motor only.

Is not guaranteed complete impermeability to rain.

mandatory column beyond w.300 cm. and d.605 cm. for module



The KE painting process includes high quality standards, with an 8-stage pre-treatment that includes degreasing, deoxidation, and protective treatments before painting. Thanks to this last phase, components and profiles are further guaranteed against particularly severe environmental situations. At the end of the process the profiles and components are painted with polyester resin-based epoxy powders. Treated components are periodically tested in salt spray according to the ISO 9227 standard to confirm conformity and consistency of the process. The European product standard EN 13561: 2015 defines corrosion resistance classes of the metal parts that make up the product according to the table below. Tests performed on the painted components and profiles allow us to classify the product in the maximum class achievable according to EN 13561: 2015, C2 / 4 (48 h - internal components, 240 h - external components).

Equipped with the most modern process control systems including continuous monitoring in which the working parameters are recorded and corrected every 2 minutes, the new painting process guarantees the high quality characteristics of the product while minimizing the risk of environmental pollution. This is a choice born from the desire to always keep up with technology while guaranteeing operator safety and low environmental impact. Thanks to nanotechnologies, the implemented coating constitutes an excellent base for anchoring paints, ensuring excellent adhesion and resisting corrosion. The plant in which aluminum or galvanized steel products with a length of up to 7 meters can be treated, includes 7 treatment tanks, 1 double compartment drying oven, 1 polymerization oven and 1 purification plant for waste water treatment. The real focus of the plant, however, is the two powder coating booths, each with 4 stations for manual retouching. The booths allow greater production continuity, thanks to a drastic reduction in required stops for color changes.

### CORROSION RESISTANCE

Classes	1	2	3	4
Internal components	24	48		
External components		48	96	240

# COLOURS

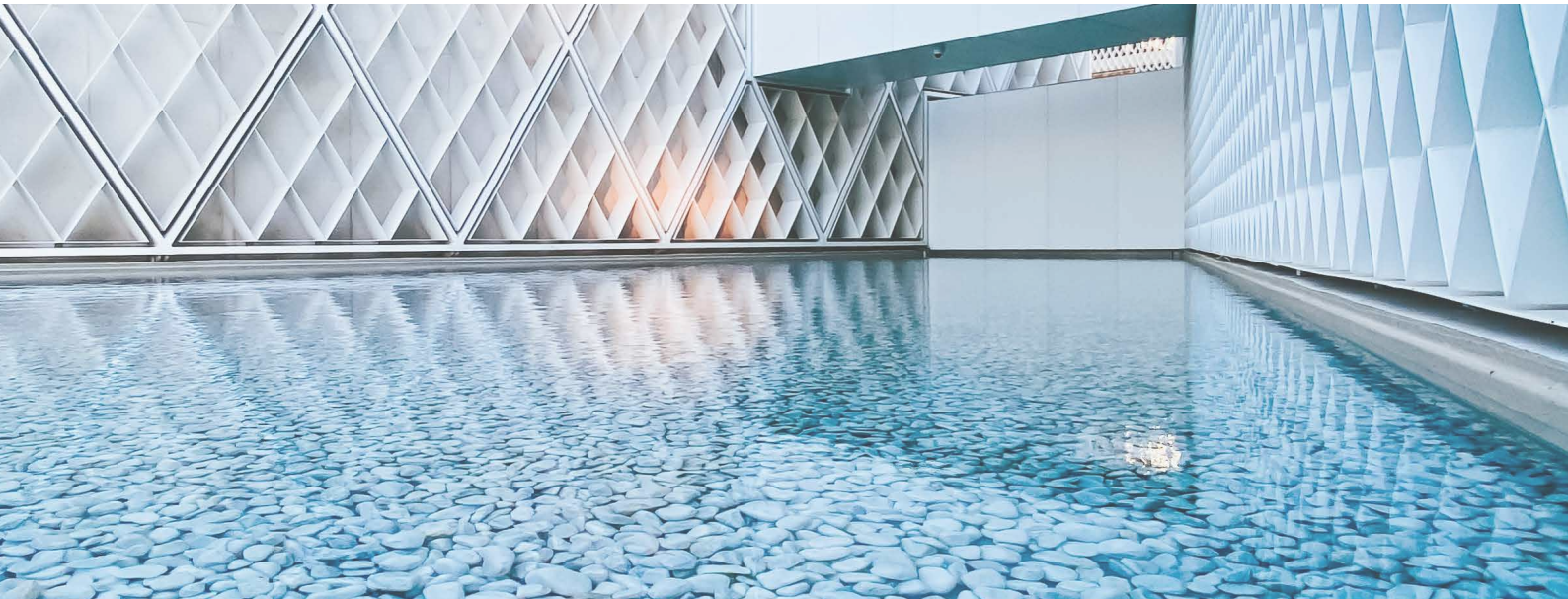

When working with color, we know that our whole world is defined by light. And color is nothing more than a breakdown of light. Objects reflect back to our eyes only the color that defines it. This is why it is so important to recognize the close link between color and matter. For this project, there are three keywords that guide the research: Words, Places, Matters.

**WORDS:** Naming colors is important to make them familiar and easily recognizable.

**PLACES:** Places define colors. Recognizing different types of places is a starting point for defining and suggesting color combinations.

**MATERIALS:** Objects do not exist in isolation, but rather match the environment around them: analyzing the materials that make up the environment itself helps us to make decisions; to decide, for example, if the character of a place is false or if instead it is genuinely artistic.

## COLOURS RAL

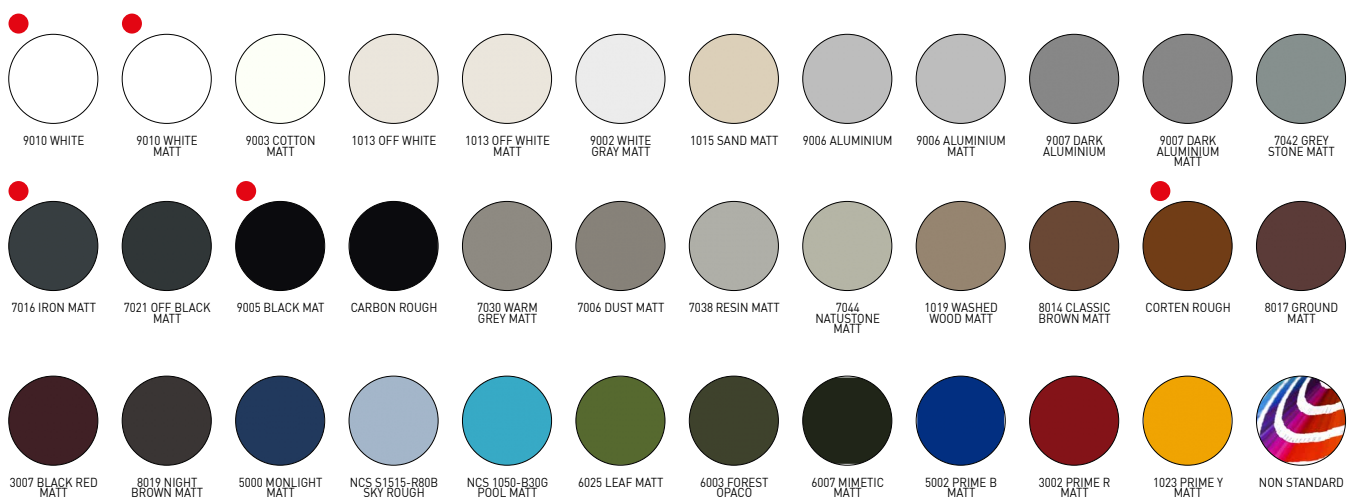

● Ral standard (without supplement)

## COLOURS

STRUCTURE COLORS	PLASTIC COLORS
RAL 9010 WHITE MATT	White
RAL 9010 WHITE	White
RAL 1013 OFF WHITE MATT	Ivory
RAL 1013 OFF WHITE	Ivory
RAL 9006 ALUMINIUM MATT	Black/Gray
RAL 9006 ALUMINIUM	Black/Gray
RAL 9007 DARK ALUMINIUM MATT	Nero
RAL 9007 DARK ALUMINIUM	Black/Gray
RAL 8014 CLASSIC BROWN MATT	Black
CORTEN ROUGH	Black
RAL 7016 IRON MATT	Black
CARBON ROUGH	Black
RAL 9005 BLACK MATT	Black
RAL 9003 COTTON MATT	White
RAL 9002 WHITE GRAY MATT	White
RAL 7038 RESIN MATT	Black/Gray
RAL 7044 NATURAL STONE MATT	Black/Gray
RAL 7030 WARM GREY MATT	Black/Gray
RAL 7042 GREY STONE MATT	Black/Gray
RAL 1015 SAND MATT	Ivory
RAL 1019 WASHED WOOD MATT	Black
RAL 7006 DUST MATT	Black
RAL 3007 BLACK RED MATT	Black
RAL 8017 GROUND MATT	Black
RAL 8019 BIGHT BROWN MATT	Black
RAL 7021 OFF BLACK MATT	Black
RAL 5000 MONLIGHT MATT	Black
NCS S1515-R80B SKY ROUGH	Black
NCS 1050-B30G POOL MATT	Black
RAL 6025 LEAF MATT	Black
RAL 6003 WOOD MATT	Black
RAL 6007 MIMETIC MATT	Black
RAL 5002 PRIME B MATT	Black
RAL 3002 PRIME R MATT	Black
RAL 1023 PRIME Y MATT	Ivory

N.B. For colors not listed, KE reserves the right to select the best possible color combination between the frame and the available plastic components.



There is increasing demand for high-performance buildings that have a very low energy consumption and use energy derived from renewable sources. In particular, the limitation of solar heat gain is one of the most important aspects of summer thermal comfort. Solar shading plays an essential role in this concept. The gtot value determines the ability of the solar shield to maintain, in an environment directly exposed to solar radiation, a more comfortable temperature than that which would occur with the presence of glass alone. The solar heat gains are directly proportional to the total transmittance of solar energy gtot, a value that depends on the glazing and external shielding. The European product standard EN 13561: 2015 and the EN 14501 standard identify 5 energy performance classes as shown in the table below.

Effect of GTOT on thermal comfort					
Gtot value	$\geq 0,50$	$\geq 0,35 \text{ e } < 0,50$	$\geq 0,15 \text{ e } < 0,35$	$\geq 0,10 \text{ e } < 0,15$	$< 0,10$
Class	0	1	2	3	4
	very mild effect	Mild effect	Moderate effect	good effect	very good effect

Each KE product has a Gtot value according to the shading fabric / profiles used. For details, refer to the information provided with the technical data sheet of the fabric and the CE label.

# OPTIONAL\_LINE GLASS



Sliding windows with frameless doors. Lower track only 18 mm high. Easy installation with left or right hand opening. Side or central closure. Packaging with aligned windows. Height adjustment up to 8 mm for each single door. Removable for easy cleaning. Closure with self-locking and / or lock. Waterproofing is not guaranteed during heavy rain or rain with wind.

## Technical Details

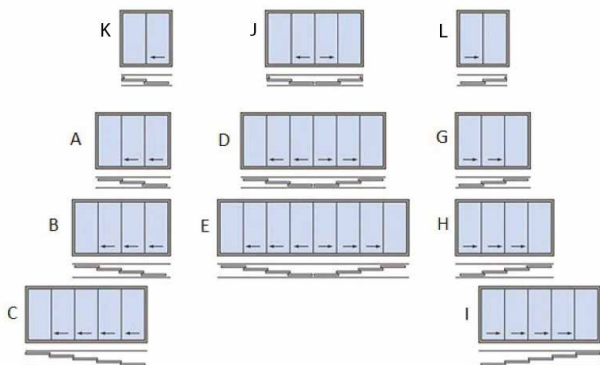
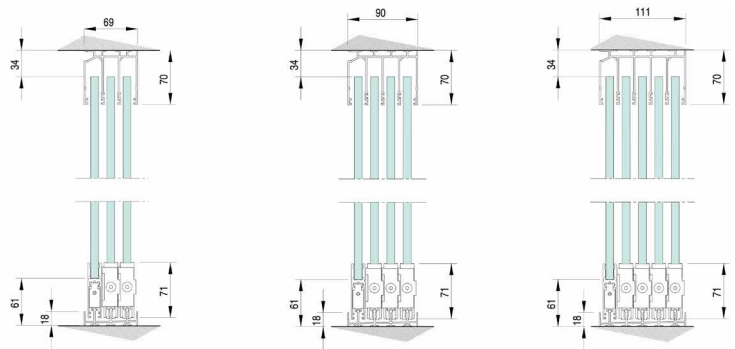



Vertika is a vertical closure that provides protection from sun and rain.  
It can be equipped with WIND BLOCK, a locking tensioning system for the fabric.  
With Vertika you can use blackout and filtering fabrics to better manage solar radiation.

- AVAILABLE:

VERTIKA SUNLIGHT

110 GPR

110 GPZ

110 GPZ H2F

130 GPR

130 GPZ



### Technical Details

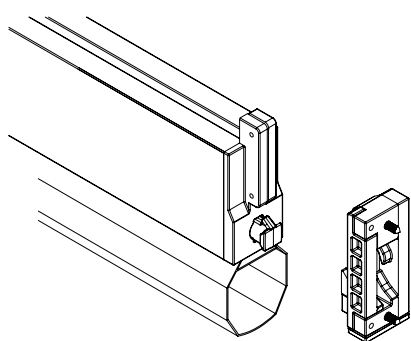

WIND BLOCK: Front bar Interlock device to be used on 100 and 130 Screeny GPZ guide, GPZ I and Gpz Unica. In wind, front bar stays locked in the low position and fabric is steadily tightened when the awning is opened completely.

# VERTIKA\_SUNLIGHT

Section

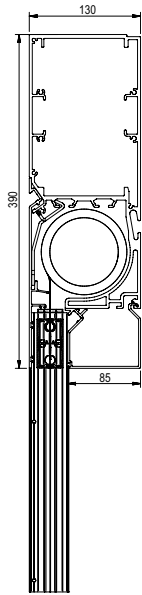

front view

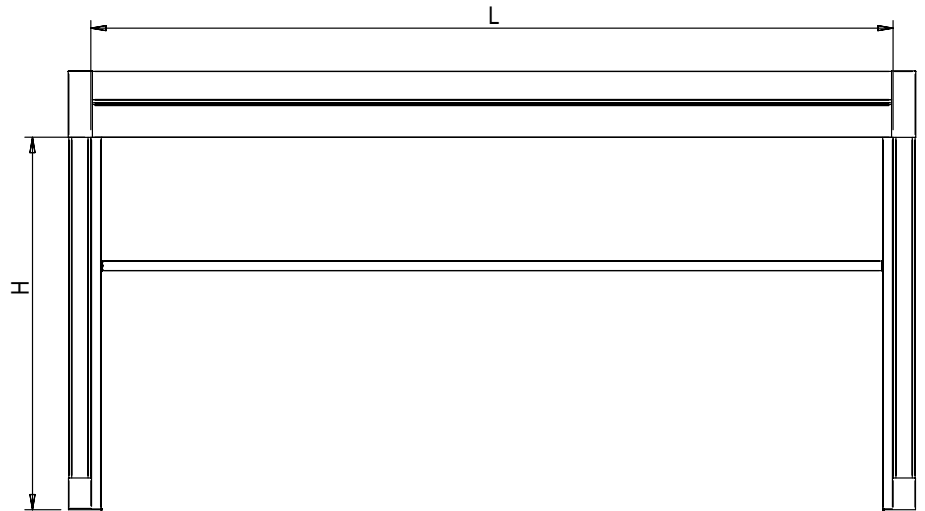

Column to column fixing

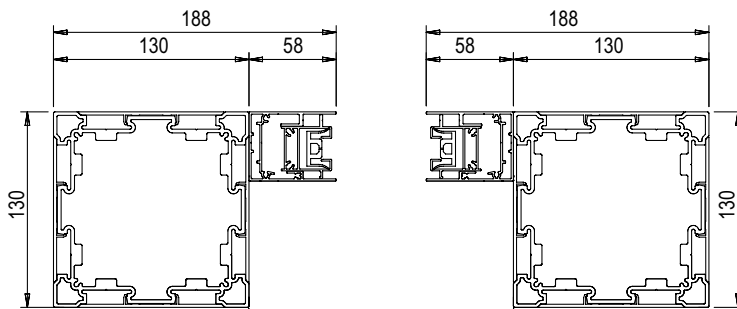

Column fixing with drain - column

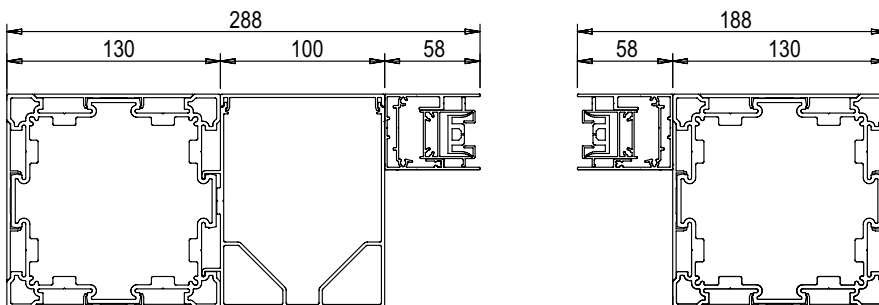

Column mounting with outlet - wall

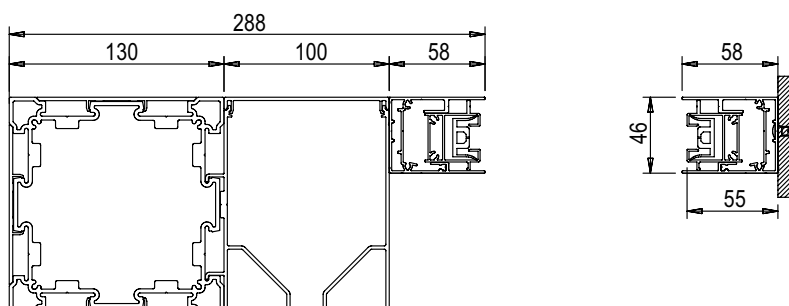

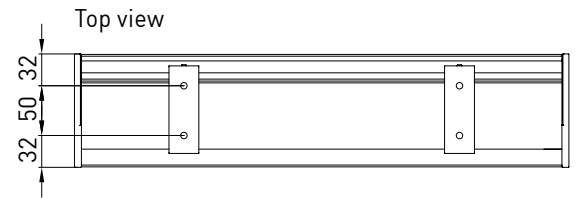
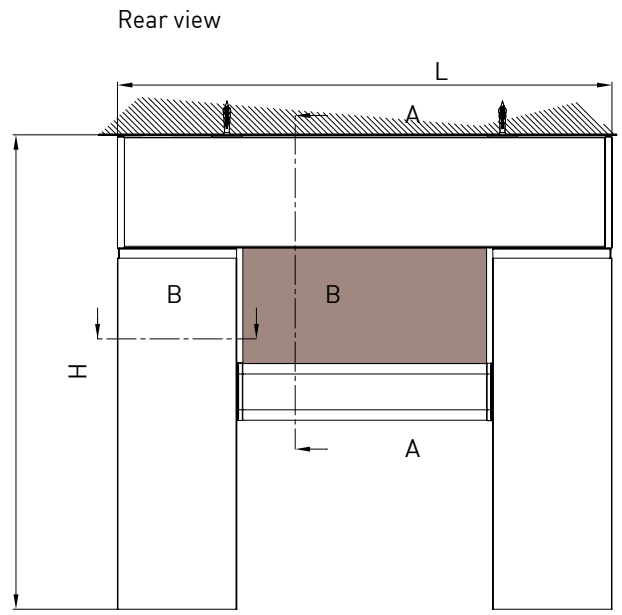
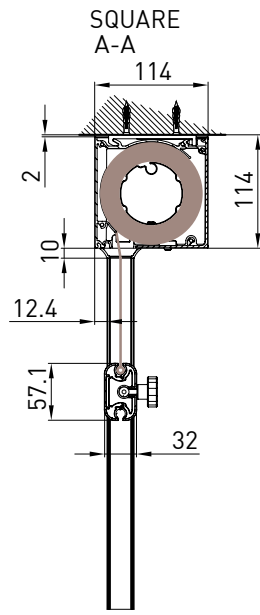
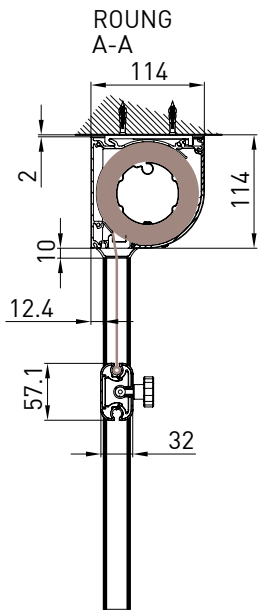

Niche guide  
B-B

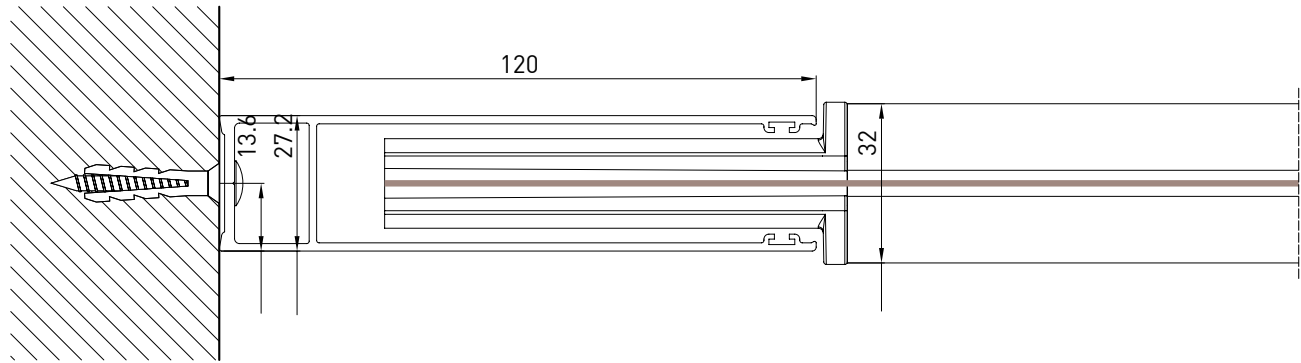

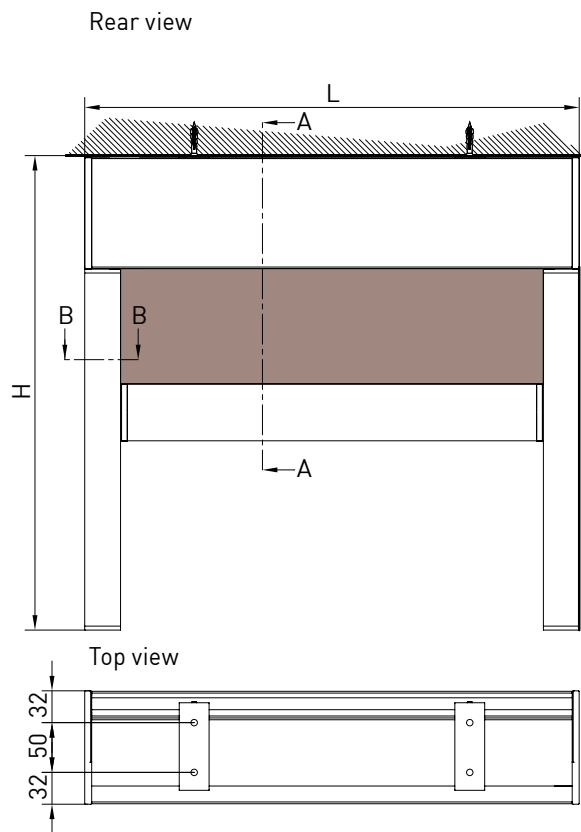
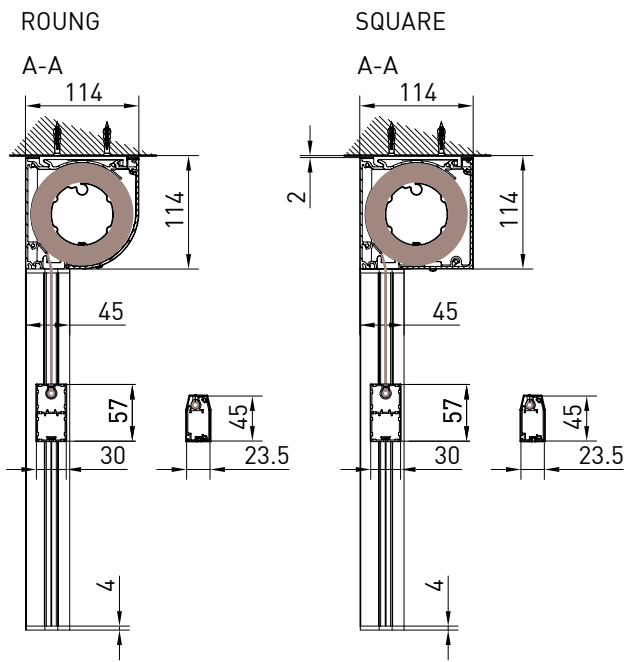

FREESTANDING - SQUARE

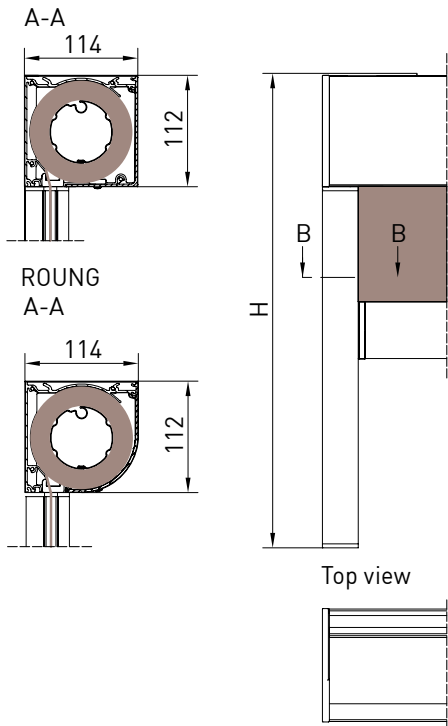

# VERTIKA\_110 GPZ

Niche guide  
B-B

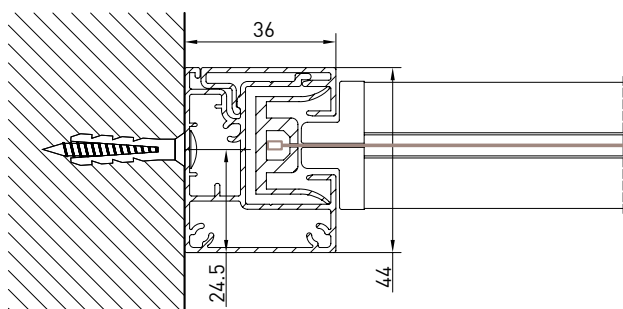

GPZ C

Niche guide  
B-B

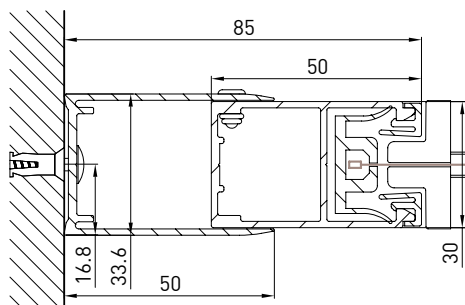

Niche guide  
B-B

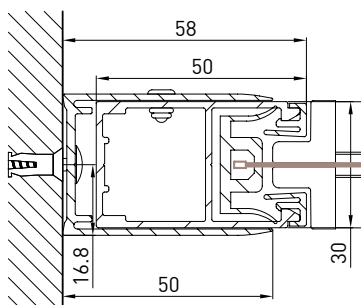

GPZ I

Niche guide  
B-B

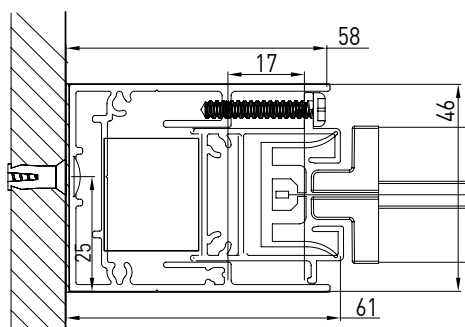

Niche guide  
B-B

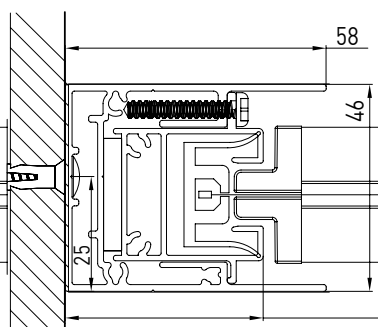

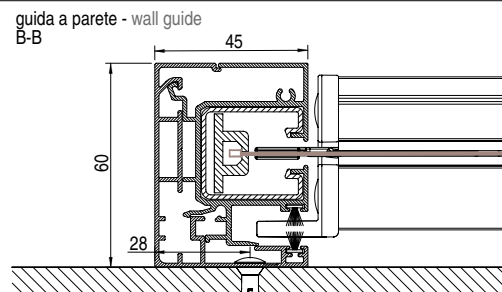
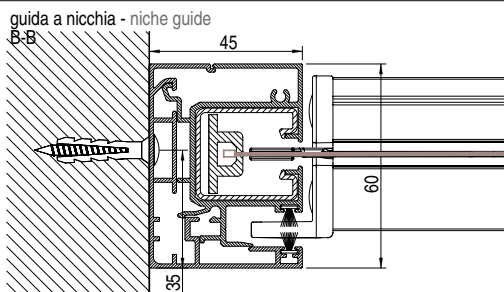
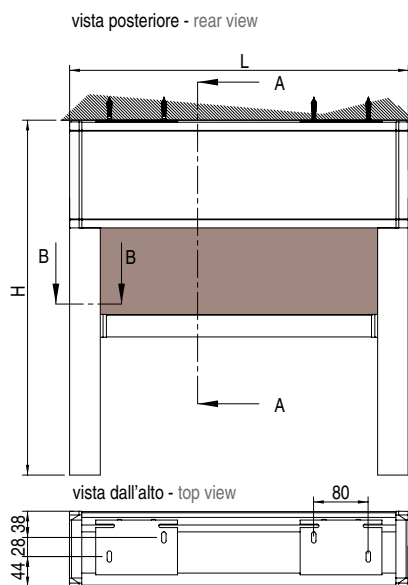
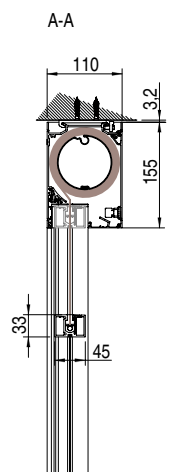

# VERTIKA\_130 GPR

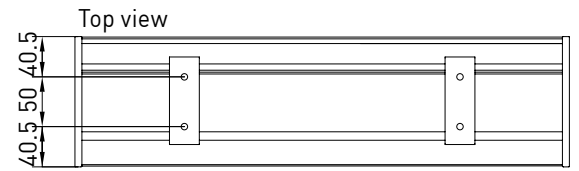
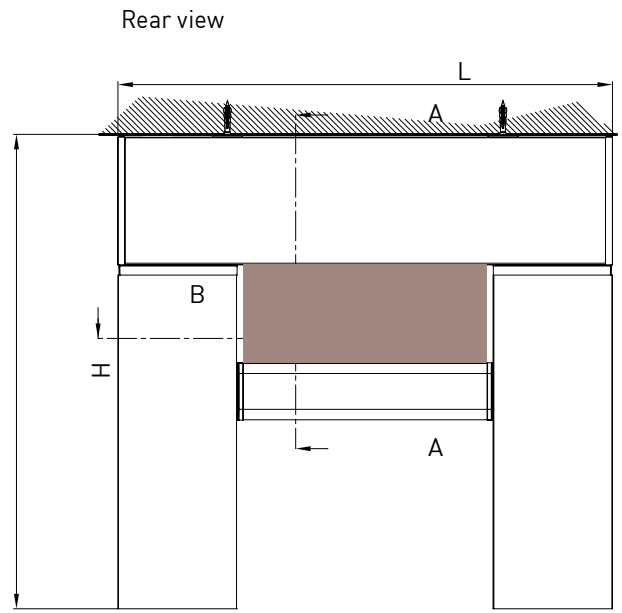
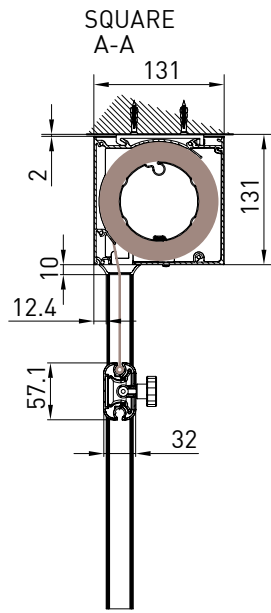
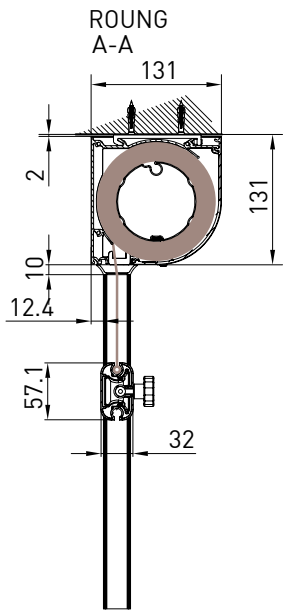

Niche guide  
B-B

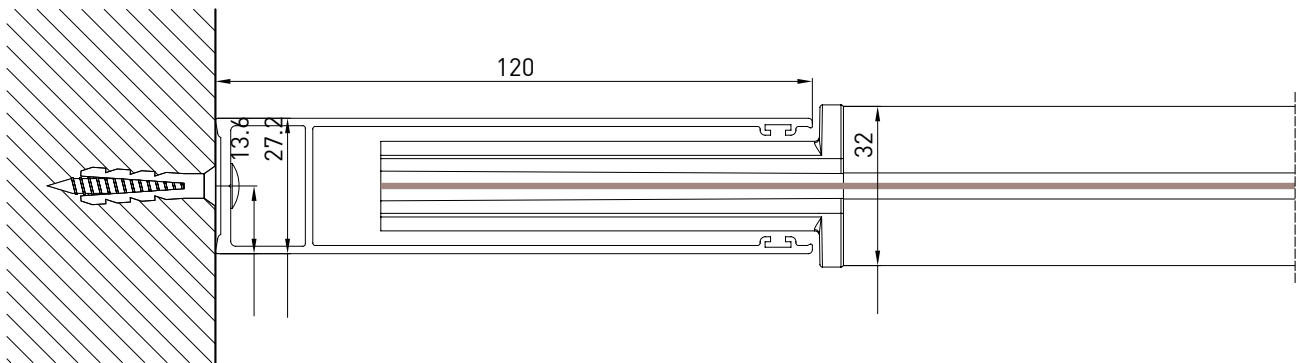

# VERTIKA\_130 GPZ

ROUNG

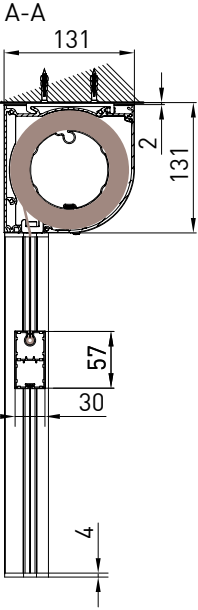

SQUARE

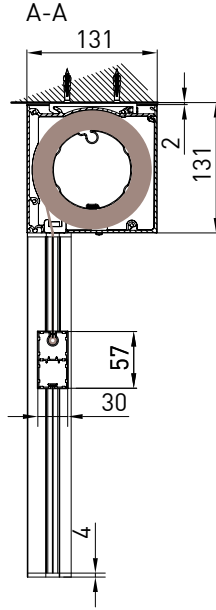

Rear view

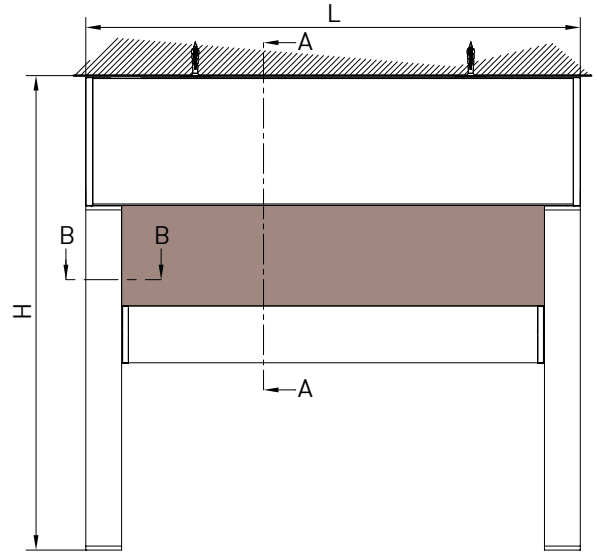

Top view

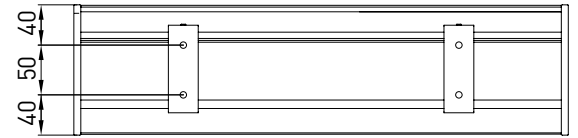

Niche guide  
B-B

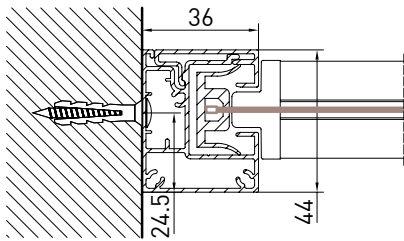

GPZ C

Wall guide (GCP)  
B-B

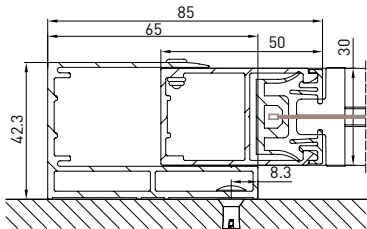

Wall guide (GCP)  
B-B

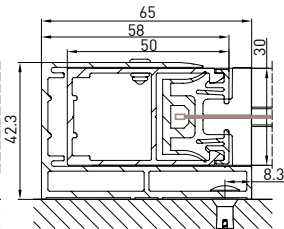

VERSIONE GPZ I

Niche guide  
B-B

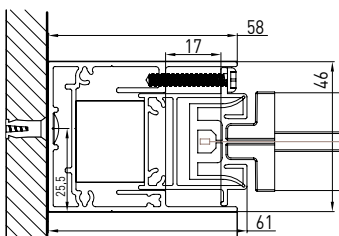

Niche guide  
B-B

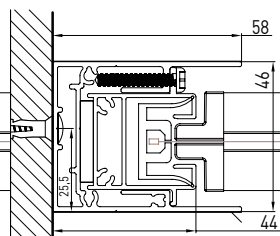

## FABRICS

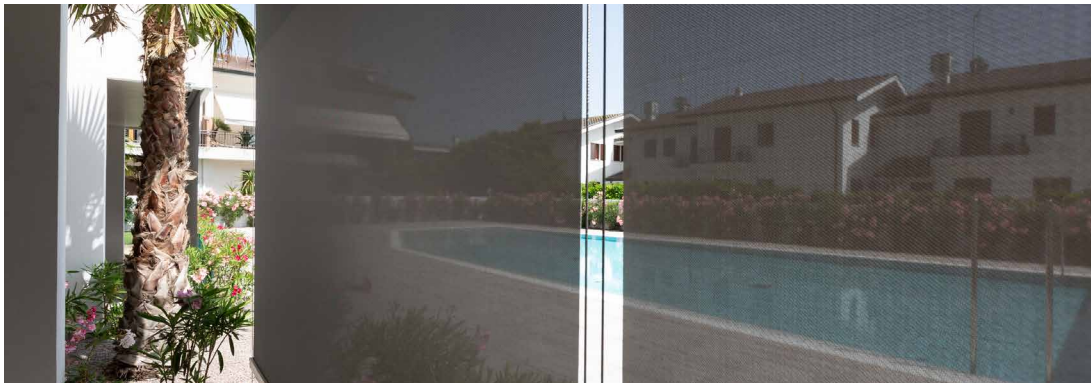

# KE

Thermal comfort blends perfectly with beautiful style thanks to the more than 500 high performance fabrics available. A wide variety of colors, styles and solar shading factors allow for a system that meets your specific needs. All fabrics are CE Certified according to the EN 13561 and EN 14501 technical standards.

N.B.  
See the Fabric Guide for further fabric specifications.

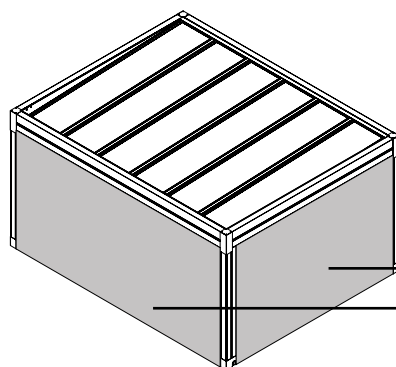

PRECONTRAIT 622 OSCURANTE  
PRECONTRAIT 302  
CRISTAL  
CRISTAL RES.  
COPACO  
STAR SCREEN  
IRISUN BLOCKOUT  
FABRINET  
ACRILICO  
SOLTIS PERFORM 92  
SOLTIS HOTIZON 86  
SOLTIS HARMONY 88  
SOLTIS OPAQUE B92  
SOLTIS PROOF W96  
OPATEX FLAT  
FABRISCREEN

### Fabrics

- PRECONTRAIT 622 OSCURANTE  
PRECONTRAIT 302  
CRISTAL  
CRISTAL RES.  
COPACO  
STAR SCREEN  
IRISUN BLOCKOUT  
FABRINET  
ACRILICO  
SOLTIS PERFORM 92  
SOLTIS HOTIZON 86  
SOLTIS HARMONY 88  
SOLTIS OPAQUE B92  
SOLTIS PROOF W96  
OPATEX FLAT  
FABRISCREEN

 0474 Dichiarazione di prestazione (DoP) rispondente a tutte le specifiche previste dall'allegato 3 CPR 305/2011 metodo di dichiarazione ZA4 3b <b>Nr. 00001-CPR-2022-05-27</b>		
Codice di identificazione unico del prodotto-tipo	<b>SUNLIGHT D55</b>	
Serial Number	Vedi etichetta apposta sul prodotto e sul manuale di uso e manutenzione	
Usò previsto del prodotto	Elementi strutturali in acciaio e alluminio per opere da costruzione	
Fabbricante	<b>KE Protezioni Solari srl</b> Via Calnova 160/A <b>30020 Noventa di Piave (VE)</b>	
Sistema di valutazione	<b>2+</b>	
Ente notificato	<b>RINA Services S.p.A</b> via Corsica, 12 - 16128 Genova (GE)	
Compiti organismo notificato	Ha effettuato l'ispezione iniziale dello stabilimento di produzione e del controllo di produzione in fabbrica, sorveglianza, valutazione e verifica continua del controllo di produzione in fabbrica secondo il sistema AVCP 2+ e ha rilasciato il certificato di conformità del controllo di produzione in fabbrica Nr: <b>0474-CPR-1261</b>	
<b>Caratteristiche essenziali</b>	<b>Prestazioni</b>	<b>Specifica tecnica armonizzata</b>
Tolleranze geometriche	EN 1090-2:2018 EN 1090-3:2019	EN 1090-1
Materiale costituente	EN 10025-2:2019 - S355JR EN 573-1 - 6082 T6	EN 1090-1
Saldabilità	EN 10025-2:2019 - S355JR EN 573-1 - 6082 T6	EN 1090-1
Resistenza a frattura	EN 10025-2:2019 - 27J AT +20°C	EN 1090-1
Reazione al fuoco	N.P.D.	
Resistenza al fuoco	N.P.D.	
Rilascio di cadmio e metalli pesanti	N.P.D.	
Radioattività	N.P.D.	
Durabilità	N.P.D.	
Portata	Vedi relazione di calcolo Nr. D55_Rev00_2022	
Resistenza a fatica	Vedi relazione di calcolo Nr. D55_Rev00_2022	
Progettazione	Rif relazione di calcolo Nr. D55_Rev00_2022	
Fabbricazione	Secondo la specifica del componente 727_00_00_00 e la EN 1090-2 / EN 1090-3	
Classe di esecuzione	EXC2	EN 1090-1
KE Protezioni Solari srl rilascia la presente dichiarazione in accordo alle Norme Europee per le costruzioni come da regolamento 305/2011; le prestazioni del prodotto identificato sono in conformità a quanto qui dichiarato. Si rilascia la presente dichiarazione sotto l'esclusiva responsabilità del fabbricante. Noventa di Piave (VE) 27/05/2022		
		Il Legale Rappresentante 

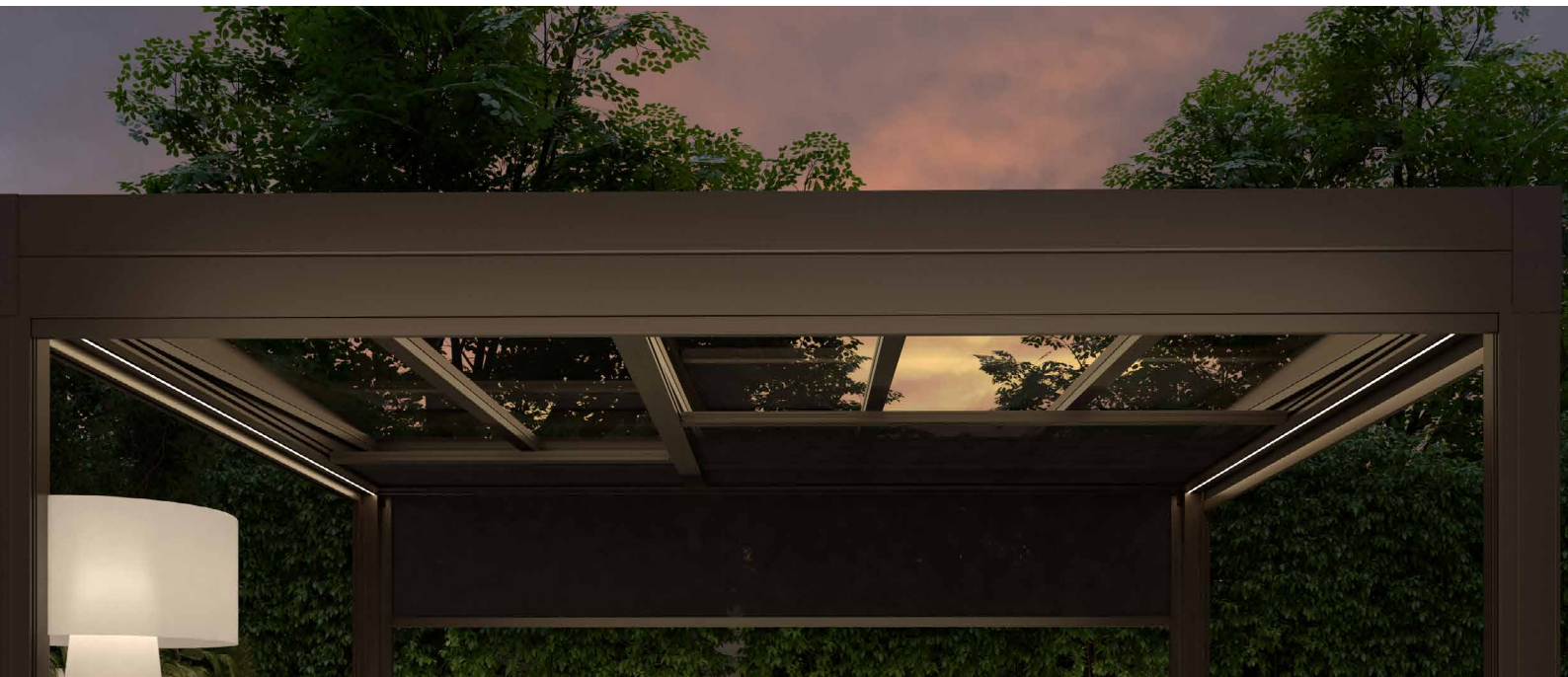

Lighting plays a very important role in allowing our pergolas to be used at any time of day. KE uses LED lights, perfectly integrated into the profiles of the structures. LED technology allows for low energy consumption, multiple applications and changes to light color and intensity using a simple remote control.

N.B.  
See the lighting guide for the other specifications.

DATI\_TECNICI:



STRIP LED	
<b>Watt</b>	10W
<b>volt</b>	24V
<b>flow</b>	830lm
<b>Color temperature</b>	3400 K
<b>LED/m</b>	98 led/m



### **EN ISO 9001 \_ Quality**

KE has adopted a Quality Management System compliant with EN ISO 9001 requirements in order to maintain and increase quality and meet the highest customer expectations. This continuous improvement, through the control of all processes and careful evaluation of risks and opportunities, engages the entire organization in the development of systems to ensure the safety and reliability of the product and in the search for innovative solutions and technologies.

### **ISO:45001:2018**

KE has activated a Safety Management System as an integral part of its work organization, committing itself to organizing the entire structure in order to pursue the objectives of continuous improvement in terms of safety and health protection. Training, knowledge and compliance with current legislation on health and safety at work, cooperation and collaboration and preventive activities are actively pursued in order to minimize the possibility of non-compliance.

### **EN ISO 14001 \_ Environment**

KE is ISO 14001 certified for environmental management and strives to be an example of respect for environmental resources and for the continuous improvement of its environmental management system. It is committed to continuous improvement and pollution prevention in compliance with applicable laws, regulations and standards; systematically detects any environmental impact of manufacturing processes, promotes the culture of recovery and recycling in the company and in the related production chain.

### **CE MARK \_ EN 13561**

The CE marking of outdoor awnings is a signal to the Consumer that the product can be sold freely in the EU single market, as it complies with Community provisions which recognize safety as the priority of every product that has this agreed upon reference standard. Verification of wind resistance capacity and the clear indication of the ability of the awning to contribute to the energy savings of the building (Gtot), are some of the commitments that the manufacturer makes to a product that has earned the CE marking. The name of the manufacturer, the reference standard (in our case EN 13561) accompany a product that is properly adapted to European indications.

### **CE MARK \_ EN 1090-1**

KE extended the CE marking in 2015 to stationary awnings, which are among the aluminum structural components covered by the international standard EN 1090-1. This marking reflects our use of rigorous structural design and manufacturing with qualified processes, adequate industrial resources and qualified personnel.

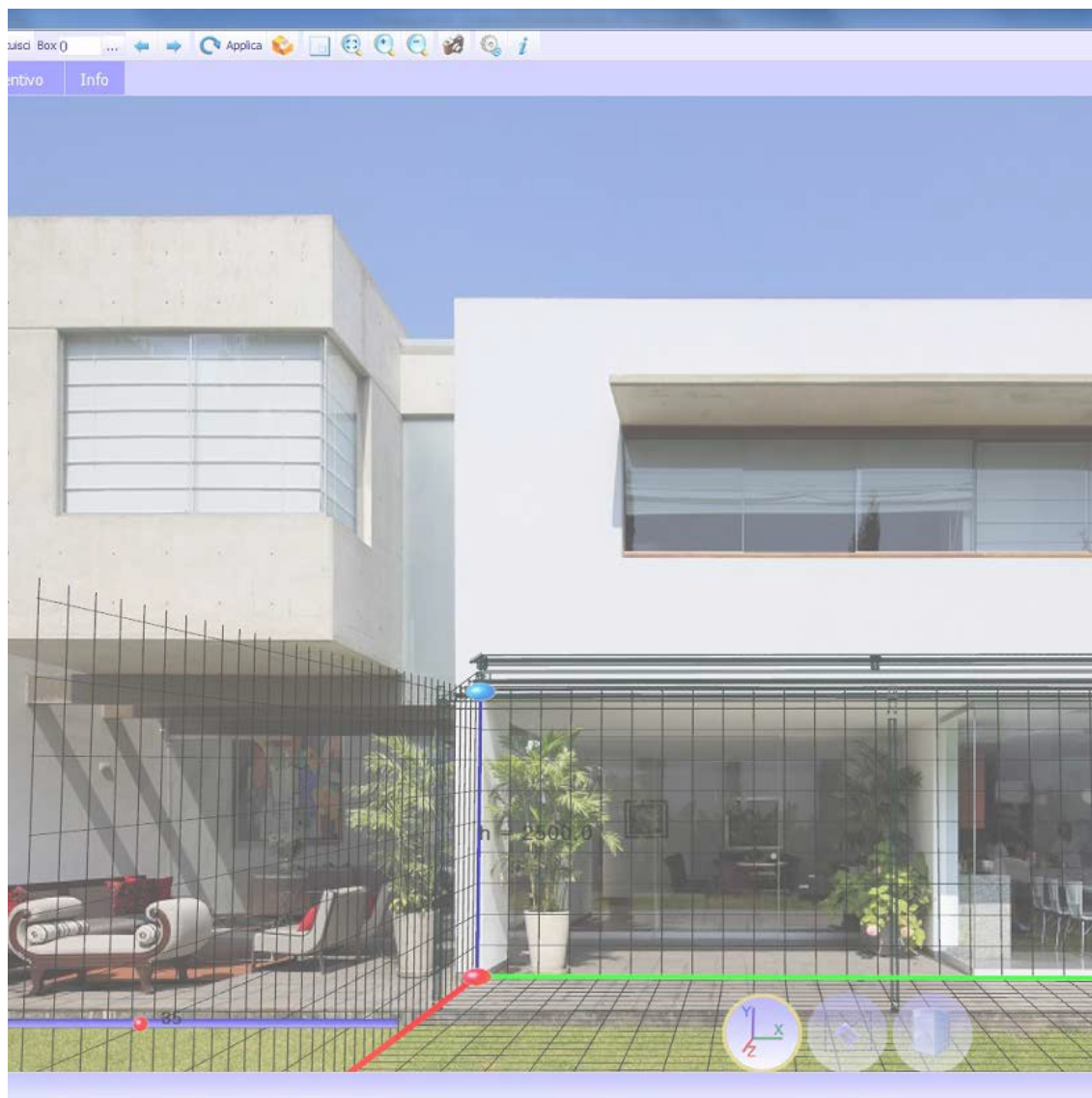

The KE B2B order system is a simple and intuitive service for placing orders conveniently online. An attractive graphic design, numerous functionalities and an easy and intuitive use mode that allows to access in real time to all the information related to the history of the orders and to the processing of the current ones. With the Cad Lite 3D Configurator you can configure Genius and Bioclimatica models thanks to a constantly updated online catalogue. Thanks to an easy-to-use interface, it also allows you to formulate a complete quote with minimal error.

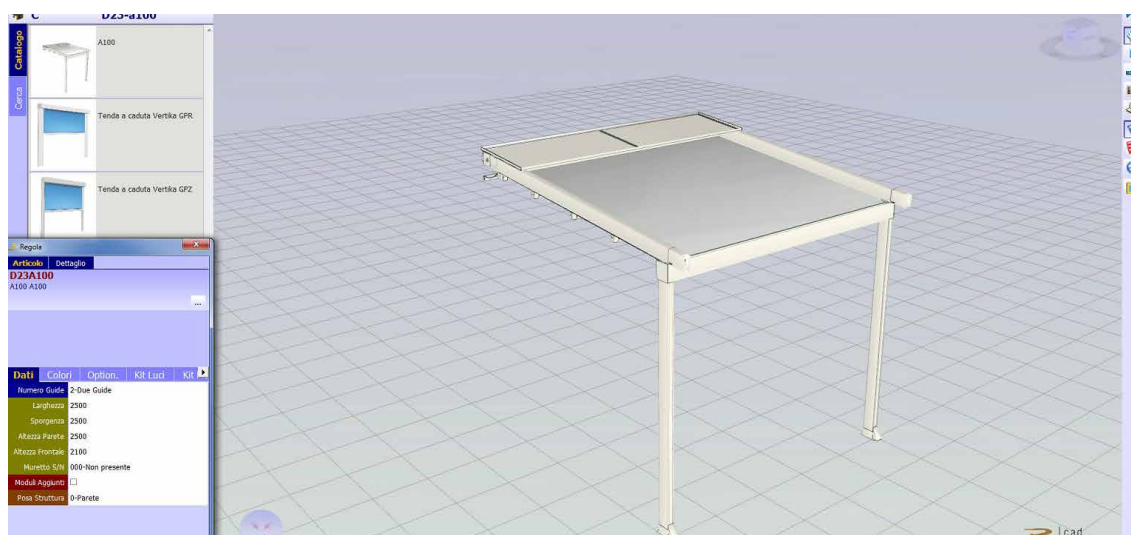

Home > Ambienti

## Ambienti

La nostra missione è creare nuovi spazi outdoor da vivere in totale armonia. Grazie alle nostre **coperture solari e alle strutture per esterni personalizzate, potrai arredare con stile il tuo terrazzo, giardino, attico, ma anche modulare...** [Leggi di più](#)



BIM technology improves the working method of designers and is now the main source of information for the realisation of a project. With BIM the model is generated in a "parametric 3D" from which a series of information such as 2D views, elevations, sections but also metric calculations and much more can be automatically derived. On the KE website you can find the BIM gallery of the main KE models, the certifications and all the useful technical documentation for each product: [www.keoutdoordesign.com](http://www.keoutdoordesign.com)

Area Clienti IT-IT

Referenze Area Media

- Brochure e Cataloghi
- BIM & 3D Models
- Blog
- News
- Video

POWERED BY SYNCRONIA



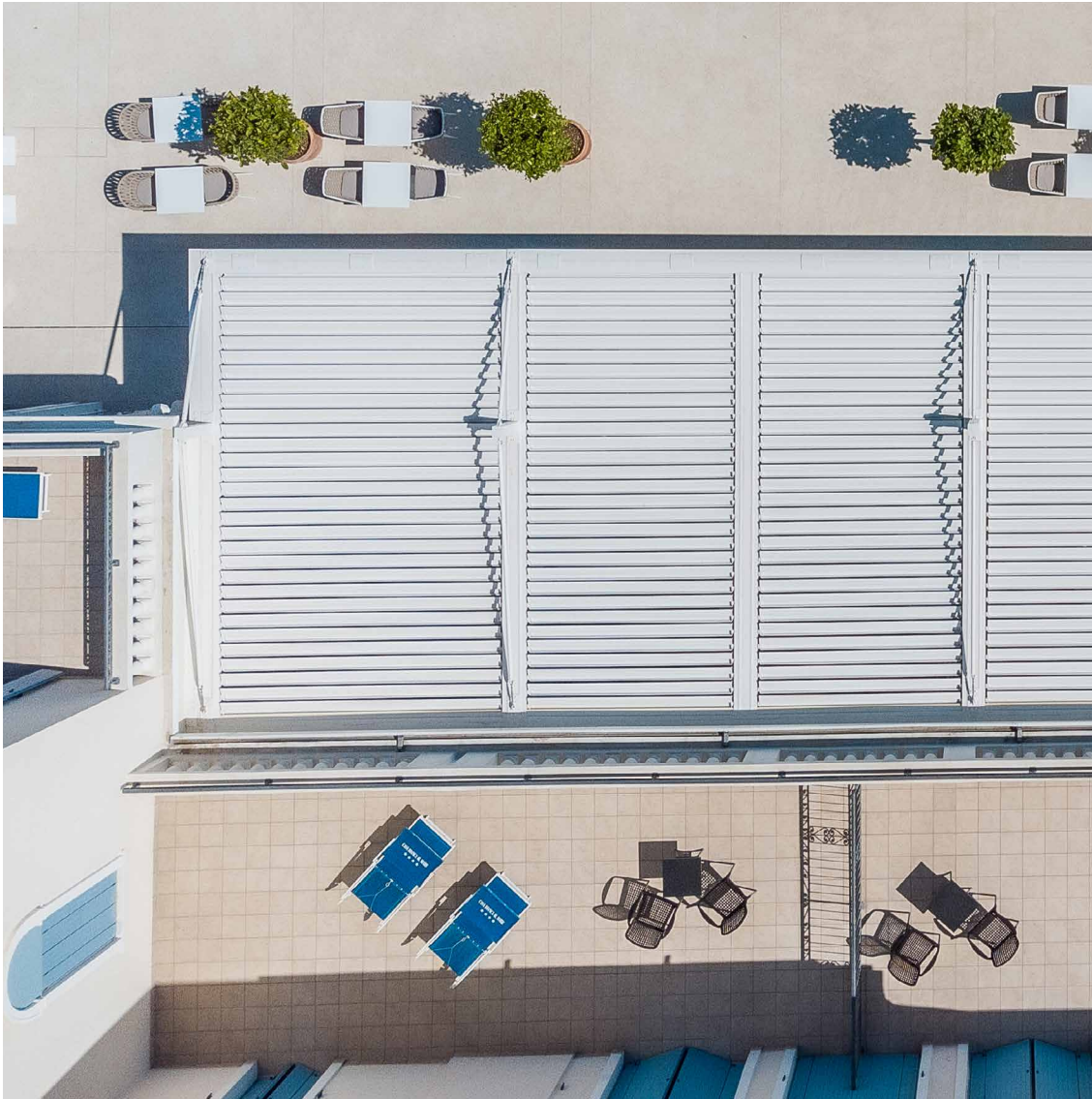

**A GROUP,  
A VISION,  
A GROUP IN EVOLUTION**

Since 1987, KE has been designing and manufacturing arm awnings, cassette awnings, drop awnings, canopies, shelters and is specialised in shading structures that enhance the liveability of outdoor spaces, up to the redesign and restyling of urban furniture. Both for the variety of the range and the depth of the configurations, KE is a manufacturing reality able to satisfy the most demanding requests the most demanding requirements of designers, architects, window and door manufacturers, upholsterers and outdoor professionals.

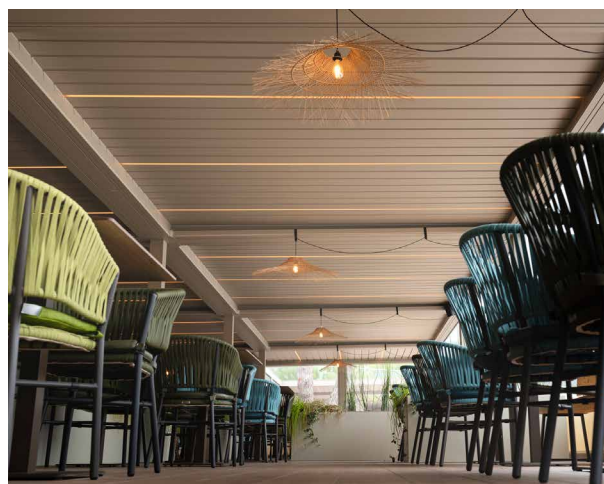

**Improving the experience**

With KE's professionalism and experience you can rely on quality products designed to enhance your customers' outdoor experience. With KE it will be easier to live the outdoor space in perfect harmony with the surrounding environment, widening the viewpoints and ensuring maximum comfort in all seasons.