

A100 LUX

20.04.2026_rev.01



KE



A100 LUX

KE



↔ 1300/500 ↙ 500/600 ↔ 155 ↘ 100

Foldable aluminum pergola awning, consisting of a fabric (tensioned when open) attached to a system of crossbars, carriages, and guides that allow it to slide horizontally.

Max dimensions 1300x600 and 1150x550 cm.

Wind resistance guaranteed up to class 6 according to EN 13561.

Guide profiles 6x11 and pillars 6x11.

Maximum column height 260.

Max coverage area 69 sqm.

It is wall, ceiling or recess-mounted via extruded aluminium or die-cast brackets.

Automatic movement by motor (optional) or with gear.

Perimeter closing options with drop screens, zip screens, sliding glass walls.

Optional kit light and music

It is possible to install light sensors and anemometers as well as connection to remote controls and control systems via smartphone apps.

Curtain profiles made from extruded aluminum alloy 6060, brackets in die-cast or shell-molded aluminum, and stainless steel screws.

Parts painted with polyester resin-based epoxy powders.

Opatex Flat are the fabrics available as standard.

The formation of condensation on the fabric is a natural phenomenon not to be considered a defect.

The standard colors are RAL 9010 White, RAL 9010 mat White, RAL 7016 Iron, rough Carbon and rough Corten.

CE marking according to EN 13561:2015.

OPTIONAL

LIGHT



GABLES



VERTIKA

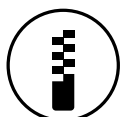

TECHNICAL INFORMATION

General technical plan

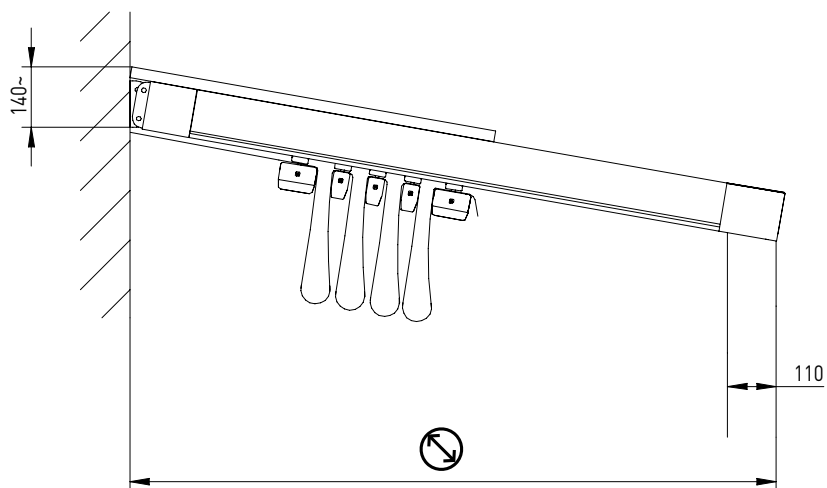

Guides interaxis width

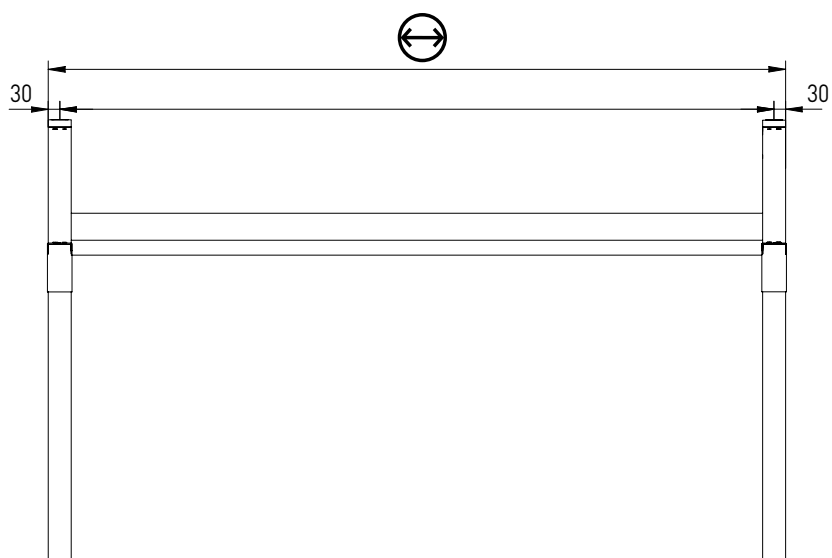

Profiles dimensions

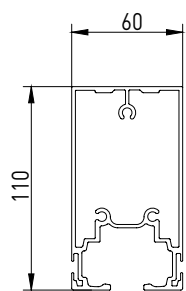

Guide

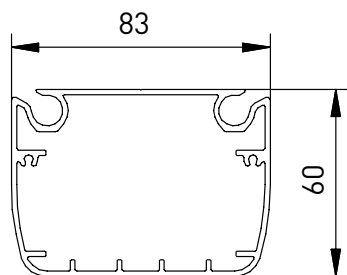

Terminal bar profile

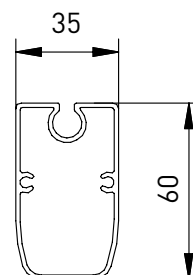

Fabric carrying Crossbar profile

TECHNICAL INFORMATION

Girder section

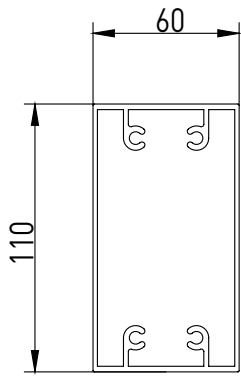

Pilar

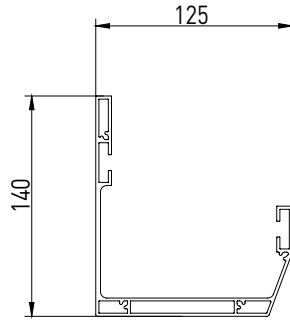

Guide support profile

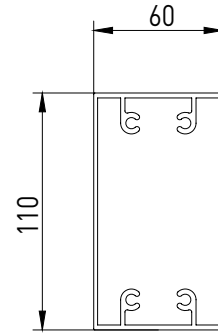

Front beam

Ground connection

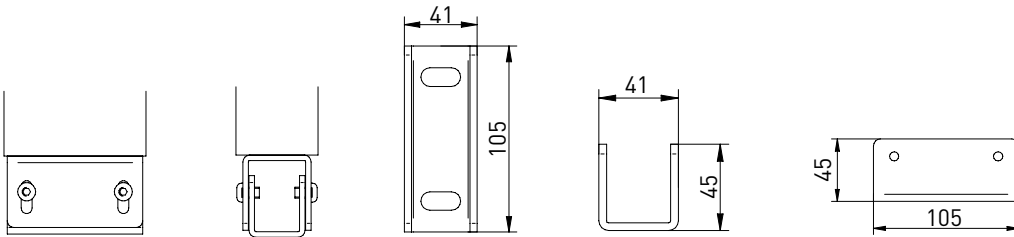

Ceiling installation

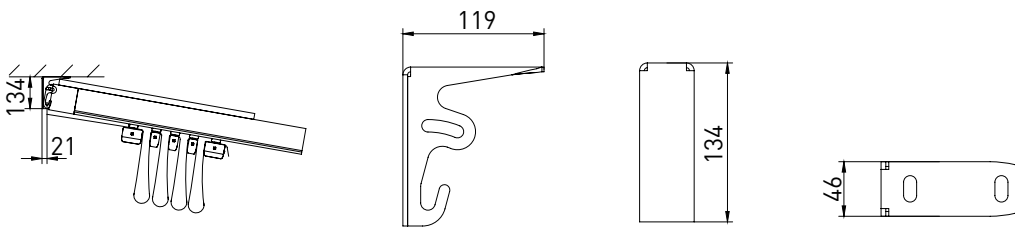

Wall installation

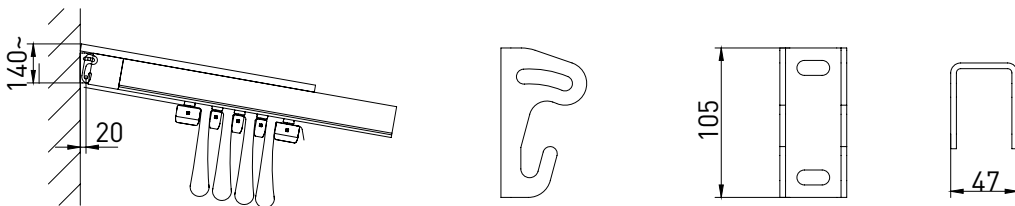

TECHNICAL INFORMATION

Cloth dimensions

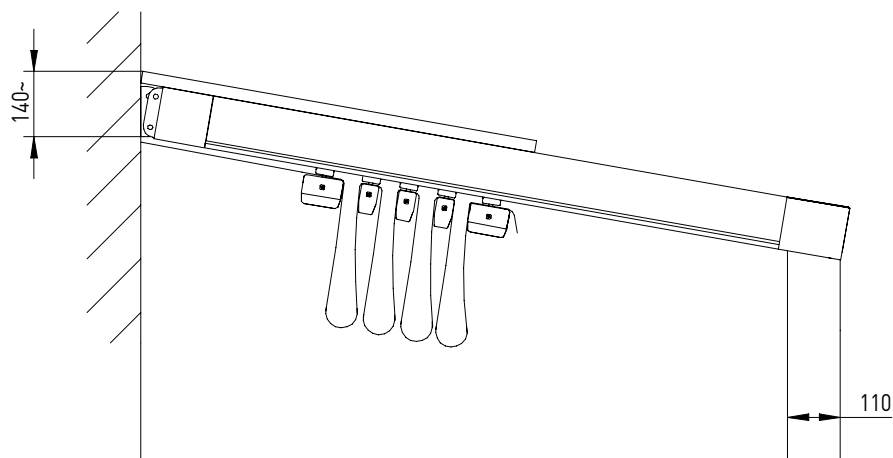

Indicative values of the fabric encumbrance and the number of the fabric carrying crossbar profiles.
Attention: the values shown may vary according to the slope.

Traverse movement

	A cm	B cm	N
250	39	50	5
300	40	55	5
350	41	60	6
400	42	66	7
450	43	71	8
500	44	71	9
550	45	76	10
600	45	81	10

Crossbar profile numbers (terminals included). Maximum interaxis fabric carrying cross bar profiles measure cm 58.

TECHNICAL INFORMATION

SLOPES

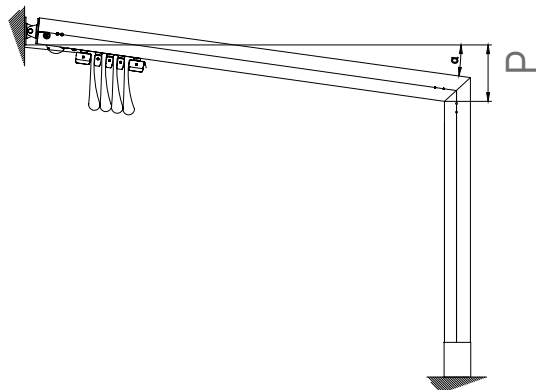

2 GUIDES	cm	P					
		250	300	350	400	450	500
		STD / I	STD / I	STD / I	STD / I	STD / I	STD / I
	150	12 / -	14 / -	16 / -	18 / 11	20 / 12	24 / 13
	200	16 / -	19 / -	22 / -	24 / 15	27 / 17	32 / 18
	250	20 / -	24 / -	27 / -	31 / 20	34 / 21	40 / 23
	300	25 / -	29 / -	33 / -	38 / 24	42 / 26	49 / 28
	350	29 / -	34 / -	39 / -	44 / 29	49 / 31	59 / 33
	400	34 / -	40 / -	45 / -	51 / 33	57 / 36	68 / 38
	450	39 / -	45 / -	52 / -	58 / 38	65 / 41	79 / 44
	500	44 / -	51 / -	58 / -	65 / 43	72 / 47	89 / 50
	550	49 / -	57 / -	65 / -	73 / 48	80 / 52	98 / 56
	600	55 / -	63 / -	71 / -	80 / 53	89 / 58	108 / 62
	650	60 / -	69 / -	78 / -	88 / 58	97 / 64	
	700	66 / -	75 / -	85 / -	95 / 64	105 / 70	
	750	71 / -	82 / -	92 / -	103 / 69	114 / 76	
	800	77 / -	88 / -	100 / -	111 / 75	122 / 83	

⊖ Projection

⊕ Width

STD
Standard

|I|
Added module

P= Minimum inclination for a correct water outflow

3 GUIDES	cm	P									
		500	550	600	650	700	750	800	850	900	
		STD / I	STD / I	STD / I	STD / I	STD / I	STD / I	STD / I	STD / I	STD / I	
	150	13 / -	15 / -	16 / 11	17 / 12	18 / 13	20 / 13	21 / 14	22 / 15	23 / 16	
	200	18 / -	20 / -	21 / 15	23 / 16	25 / 17	26 / 18	28 / 19	30 / 20	31 / 21	
	250	23 / -	25 / -	27 / 19	29 / 21	31 / 22	33 / 23	35 / 24	37 / 25	39 / 27	
	300	28 / -	31 / -	33 / 24	35 / 25	38 / 27	40 / 28	42 / 29	45 / 31	47 / 32	
	350	33 / -	36 / -	39 / 28	42 / 30	44 / 31	47 / 33	50 / 35	53 / 37	56 / 38	
	400	39 / -	42 / -	45 / 33	48 / 35	51 / 37	54 / 38	58 / 40	61 / 42	64 / 44	
	450	44 / -	48 / -	51 / 37	55 / 40	58 / 42	62 / 44	65 / 46	69 / 48	72 / 51	
	500	50 / -	54 / -	58 / 42	62 / 45	65 / 47	69 / 49	73 / 52	77 / 54	81 / 57	
	550	56 / -	60 / -	64 / 47	68 / 50	73 / 52	77 / 55	81 / 58	85 / 61	89 / 63	
	600	62 / -	66 / -	71 / 52	75 / 55	80 / 58	84 / 61	89 / 64	94 / 67	98 / 70	
	650	68 / -	73 / -	78 / 57	83 / 60	87 / 64	92 / 67	97 / 70	102 / 74	107 / 77	
	700	74 / -	80 / -	85 / 63	90 / 66	95 / 70	100 / 73	105 / 77	111 / 80	116 / 84	
	750	81 / -	86 / -	92 / 68	97 / 72	103 / 76	108 / 79	114 / 83	119 / 87	125 / 91	
	800	88 / -	93 / -	99 / 74	105 / 78	111 / 82	116 / 86	122 / 90	128 / 94	134 / 98	

4 GUIDES	cm	P							
		950	1000	1050	1100	1150	1200	1250	1300
		STD / I	STD / I	STD / I	STD / I	STD / I	STD / I	STD / I	STD / I
	150	16 / 13	17 / 13	17 / 14	18 / 14	19 / 15	20 / 15	21 / 16	21 / 17
	200	21 / 17	22 / 18	23 / 19	25 / 19	26 / 20	27 / 21	28 / 22	29 / 22
	250	27 / 22	28 / 23	30 / 24	31 / 25	32 / 26	34 / 27	35 / 28	36 / 28
	300	33 / 26	35 / 28	36 / 29	38 / 30	39 / 31	41 / 32	42 / 34	44 / 35
	350	39 / 31	41 / 33	43 / 34	45 / 36	46 / 37	48 / 38	50 / 40	52 / 41
	400	45 / 36	47 / 38	49 / 40	51 / 41	54 / 43	56 / 44	58 / 46	60 / 48
	450	52 / 42	54 / 43	56 / 45	59 / 47	61 / 49	63 / 51	66 / 53	68 / 54
	500	58 / 47	61 / 49	63 / 51	66 / 53	68 / 55	71 / 57	74 / 59	76 / 61
	550	65 / 52	68 / 55	70 / 57	73 / 59	76 / 62	79 / 64	82 / 66	85 / 69
	600	71 / 58	75 / 60	78 / 63	81 / 65	84 / 68	87 / 71	90 / 73	94 / 76
	650	78 / 63	82 / 66	85 / 69	89 / 72	92 / 75	95 / 78	99 / 80	102 / 83
	700	85 / 69	89 / 72	93 / 75	96 / 79	100 / 82	104 / 85	108 / 88	111 / 91
	750	93 / 75	97 / 79	101 / 82	104 / 85	108 / 89	112 / 92	116 / 95	120 / 99
	800	100 / 81	104 / 85	108 / 89	113 / 92	117 / 96	121 / 99	125 / 103	130 / 107

In the situation where the modules are asymmetric, the minimum slope to consider is determined by the module with the larger width, taken as the single module. In this case, the single module to consider was the 500x650cm module

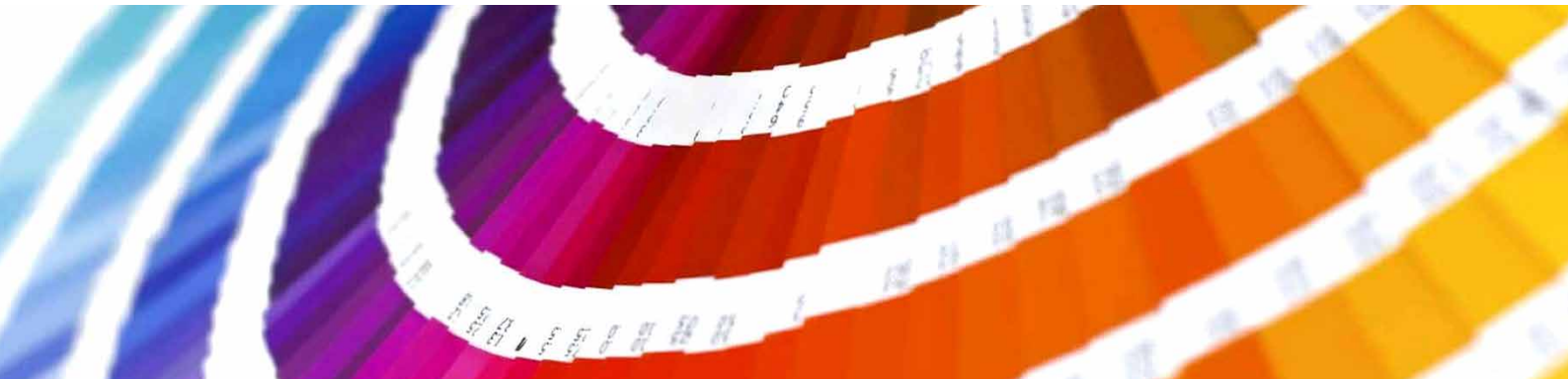

The KE painting process includes high quality standards, with an 8-stage pre-treatment that includes degreasing, deoxidation, and protective treatments before painting. Thanks to this last phase, components and profiles are further guaranteed against particularly severe environmental situations. At the end of the process the profiles and components are painted with polyester resin-based epoxy powders. Treated components are periodically tested in salt spray according to the ISO 9227 standard to confirm conformity and consistency of the process. The European product standard EN 13561: 2015 defines corrosion resistance classes of the metal parts that make up the product according to the table below. Tests performed on the painted components and profiles allow us to classify the product in the maximum class achievable according to EN 13561: 2015, C2 / 4 (48 h - internal components, 240 h - external components).

Equipped with the most modern process control systems including continuous monitoring in which the working parameters are recorded and corrected every 2 minutes, the new painting process guarantees the high quality characteristics of the product while minimizing the risk of environmental pollution. This is a choice born from the desire to always keep up with technology while guaranteeing operator safety and low environmental impact. Thanks to nanotechnologies, the implemented coating constitutes an excellent base for anchoring paints, ensuring excellent adhesion and resisting corrosion. The plant in which aluminum or galvanized steel products with a length of up to 7 meters can be treated, includes 7 treatment tanks, 1 double compartment drying oven, 1 polymerization oven and 1 purification plant for waste water treatment. The real focus of the plant, however, is the two powder coating booths, each with 4 stations for manual retouching. The booths allow greater production continuity, thanks to a drastic reduction in required stops for color changes.

CORROSION RESISTANCE

Classes	1	2	3	4
Internal components	24	48		
External components		48	96	240

COLOURS



When working with color, we know that our whole world is defined by light. And color is nothing more than a breakdown of light. Objects reflect back to our eyes only the color that defines it. This is why it is so important to recognize the close link between color and matter. For this project, there are three keywords that guide the research: Words, Places, Matters.

WORDS: Naming colors is important to make them familiar and easily recognizable.

PLACES: Places define colors. Recognizing different types of places is a starting point for defining and suggesting color combinations.

MATERIALS: Objects do not exist in isolation, but rather match the environment around them: analyzing the materials that make up the environment itself helps us to make decisions; to decide, for example, if the character of a place is false or if instead it is genuinely artistic.

COLOURS RAL



Ral standard (without supplement)

COLOURS

STRUCTURE COLORS	PLASTIC COLORS
RAL 9010 WHITE MATT	White
RAL 9010 WHITE	White
RAL 1013 OFF WHITE MATT	Ivory
RAL 1013 OFF WHITE	Ivory
RAL 9006 ALUMINIUM MATT	Black/Gray
RAL 9006 ALUMINIUM	Black/Gray
RAL 9007 DARK ALUMINIUM MATT	Nero
RAL 9007 DARK ALUMINIUM	Black/Gray
RAL 8014 CLASSIC BROWN MATT	Black
CORTEN ROUGH	Black
RAL 7016 IRON MATT	Black
CARBON ROUGH	Black
RAL 9005 BLACK MATT	Black
RAL 9003 COTTON MATT	White
RAL 9002 WHITE GRAY MATT	White
RAL 7038 RESIN MATT	Black/Gray
RAL 7044 NATURAL STONE MATT	Black/Gray
RAL 7030 WARM GREY MATT	Black/Gray
RAL 7042 GREY STONE MATT	Black/Gray
RAL 1015 SAND MATT	Ivory
RAL 1019 WASHED WOOD MATT	Black
RAL 7006 DUST MATT	Black
RAL 3007 BLACK RED MATT	Black
RAL 8017 GROUND MATT	Black
RAL 8019 BIGHT BROWN MATT	Black
RAL 7021 OFF BLACK MATT	Black
RAL 5000 MONLIGHT MATT	Black
NCS S1515-R80B SKY ROUGH	Black
NCS 1050-B30G POOL MATT	Black
RAL 6025 LEAF MATT	Black
RAL 6003 WOOD MATT	Black
RAL 6007 MIMETIC MATT	Black
RAL 5002 PRIME B MATT	Black
RAL 3002 PRIME R MATT	Black
RAL 1023 PRIME Y MATT	Ivory

N.B. For colors not listed, KE reserves the right to select the best possible color combination between the frame and the available plastic components.



There is increasing demand for high-performance buildings that have a very low energy consumption and use energy derived from renewable sources. In particular, the limitation of solar heat gain is one of the most important aspects of summer thermal comfort. Solar shading plays an essential role in this concept. The gtot value determines the ability of the solar shield to maintain, in an environment directly exposed to solar radiation, a more comfortable temperature than that which would occur with the presence of glass alone. The solar heat gains are directly proportional to the total transmittance of solar energy gtot, a value that depends on the glazing and external shielding. The European product standard EN 13561: 2015 and the EN 14501 standard identify 5 energy performance classes as shown in the table below.

Effect of GTOT on thermal comfort					
Gtot value	$\geq 0,50$	$\geq 0,35 \text{ e } < 0,50$	$\geq 0,15 \text{ e } < 0,35$	$\geq 0,10 \text{ e } < 0,15$	$< 0,10$
Class	0	1	2	3	4
	very mild effect	Mild effect	Moderate effect	good effect	very good effect

Each KE product has a Gtot value according to the shading fabric / profiles used. For details, refer to the information provided with the technical data sheet of the fabric and the CE label.



Vertika is a vertical closure that provides protection from sun and rain.
It can be equipped with WIND BLOCK, a locking tensioning system for the fabric.
With Vertika you can use blackout and filtering fabrics to better manage solar radiation.

- AVAILABLE:
110 GPR
110 GPZ
110 GPZ H2F



Technical Details

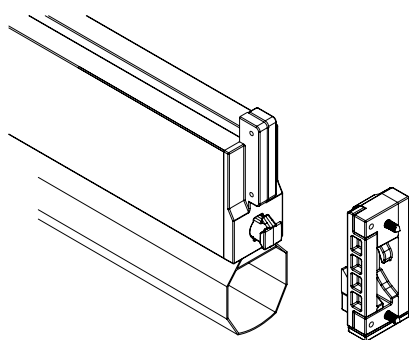

WIND BLOCK: Front bar Interlock device to be used on 100 and 130 Screeny GPZ guide, GPZ I and Gpz Unica. In wind, front bar stays locked in the low position and fabric is steadily tightened when the awning is opened completely.

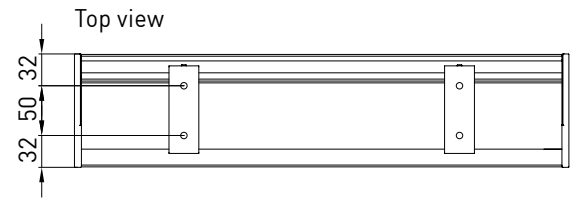
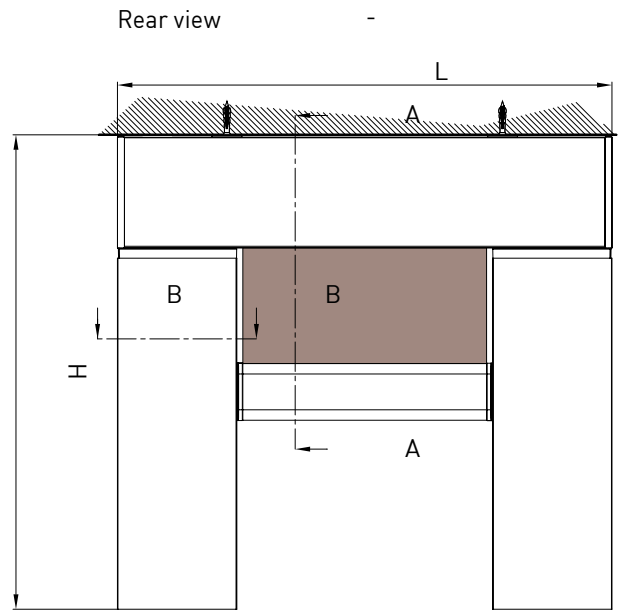
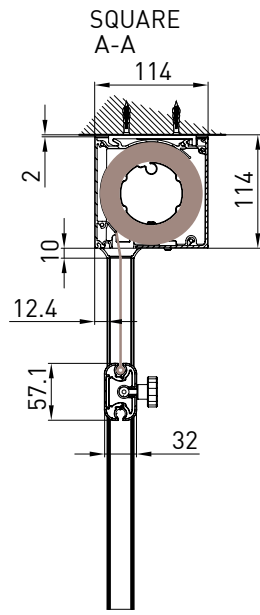
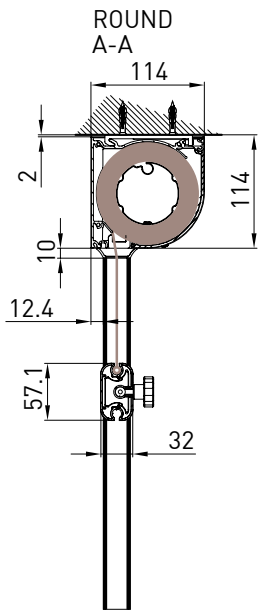

Niche guide
B-B

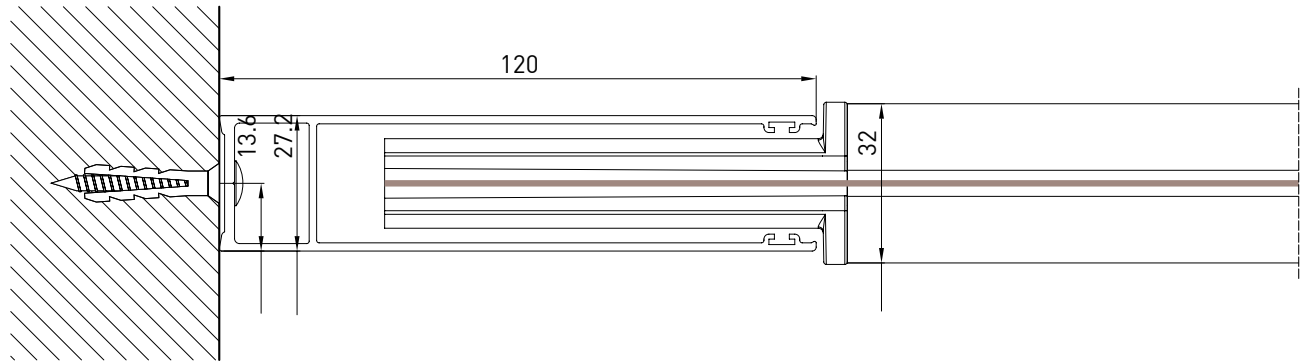

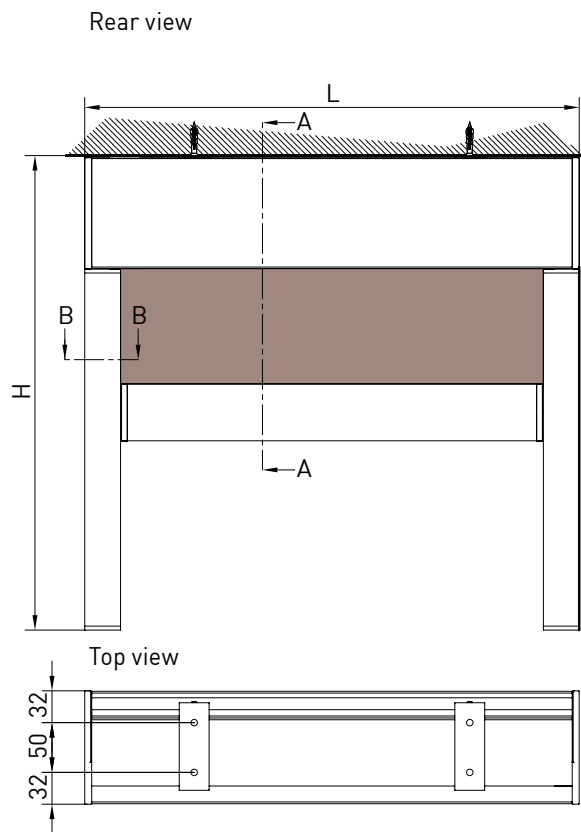
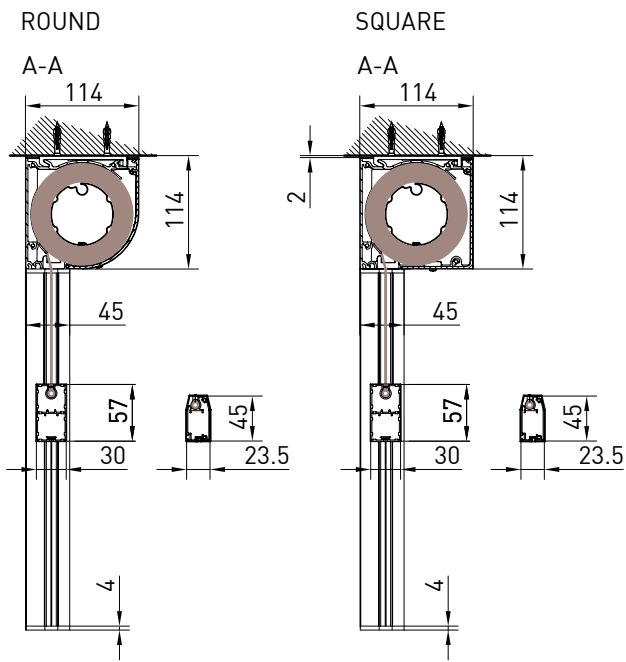

FREESTANDING - SQUARE

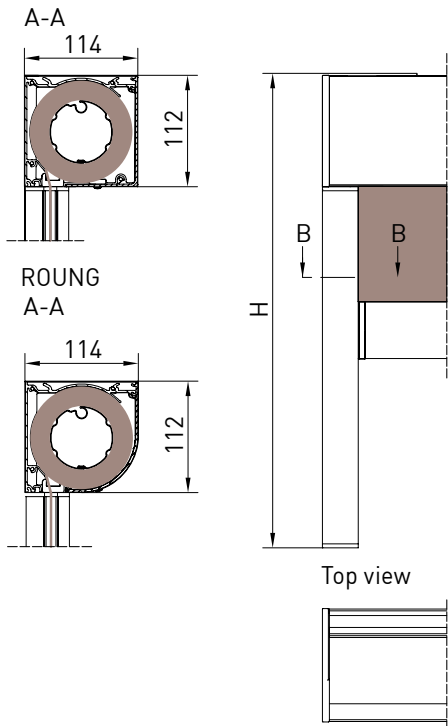

VERTIKA_110 GPZ

Niche guide
B-B

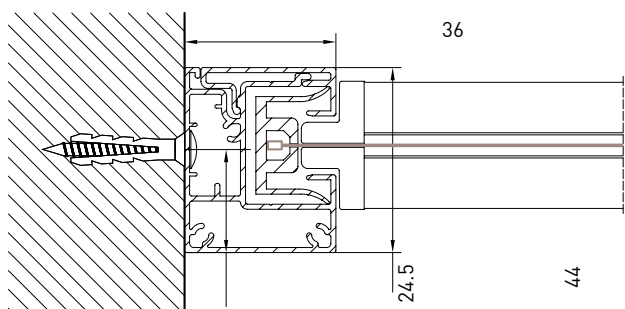

GPZ C

Niche guide
B-B

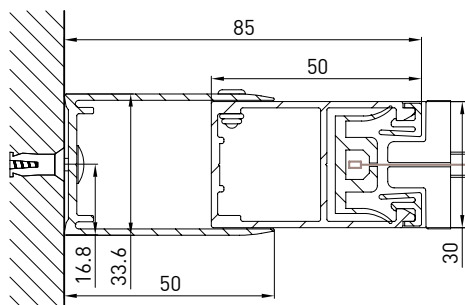

Niche guide
B-B

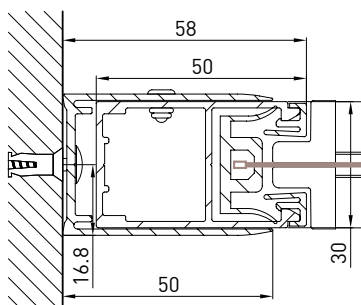

GPZ I

Niche guide
B-B

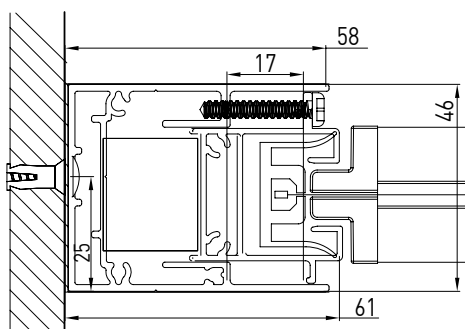

Niche guide
B-B

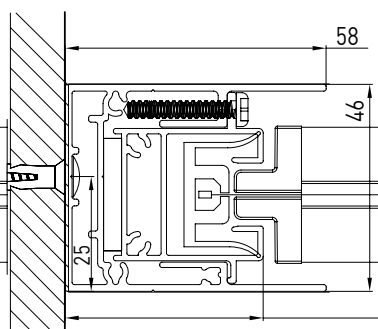

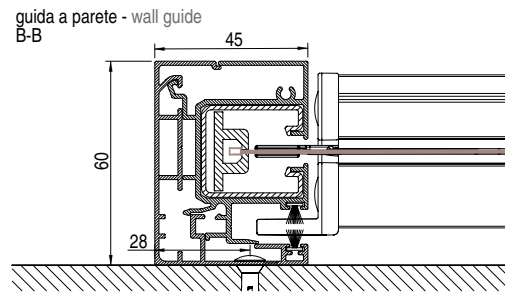
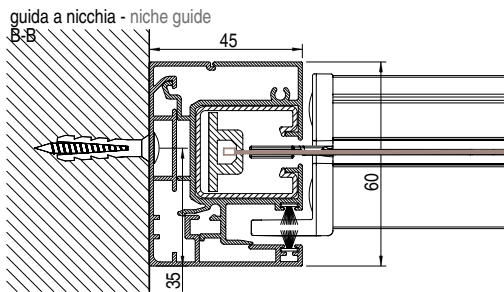
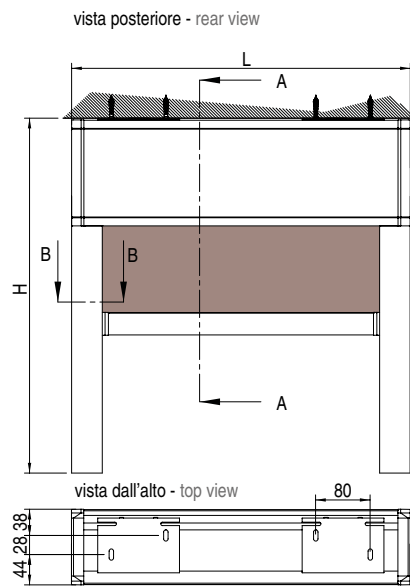
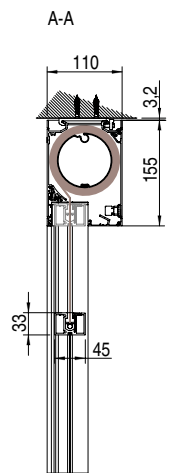

OPTIONAL SIDE CLOSURES _ DOORS AND CURTAINS



The doors have been designed to provide protection from water and wind. They are made from extruded aluminum alloy profiles (EN-AW 6060-T6) and 4 + 4 pvd 0.76 safety and shatterproof laminated glass in accordance with UNI 7697 2014. Doors are available in either one or two door versions.

The interior of the structure can be enhanced with decorative curtains. That extra romantic touch which will surely be appreciated by anyone looking for a little privacy or who want "a room all to themselves".

SPECIAL STRUCTURES

The technical office is available for assistance with non-standard structures such as some examples shown below. KE can also produce special brackets on request.

Cantilevered

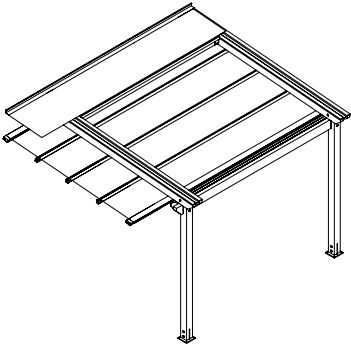

Cantilevered with recess

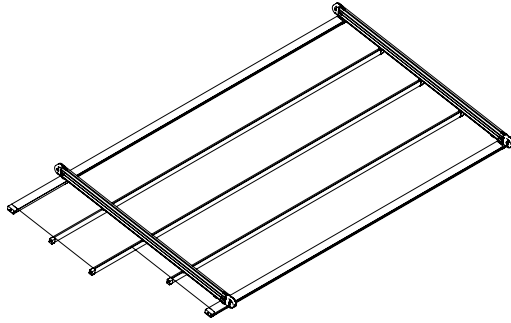

Cantilevered with recess

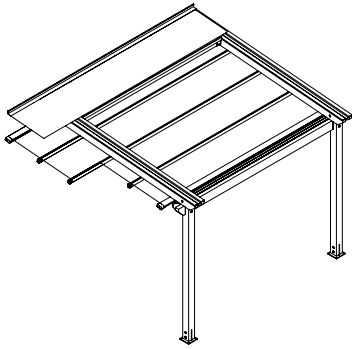

Slanting

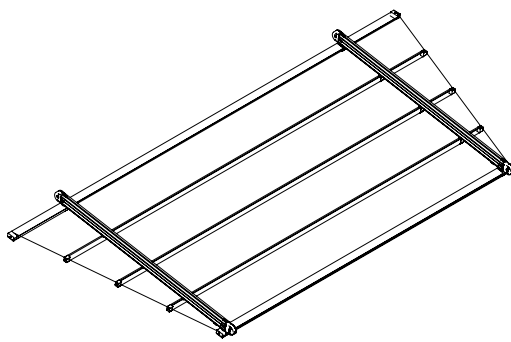

Slanting

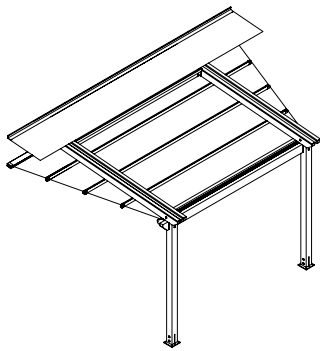

Cantilevered

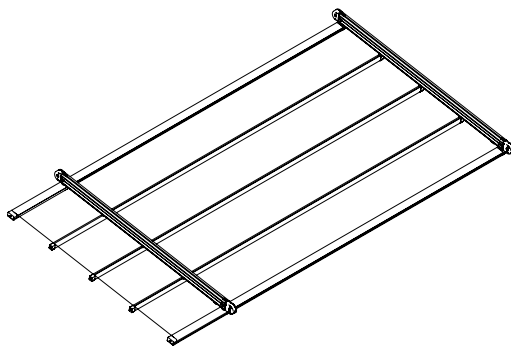

KE

FABRICS

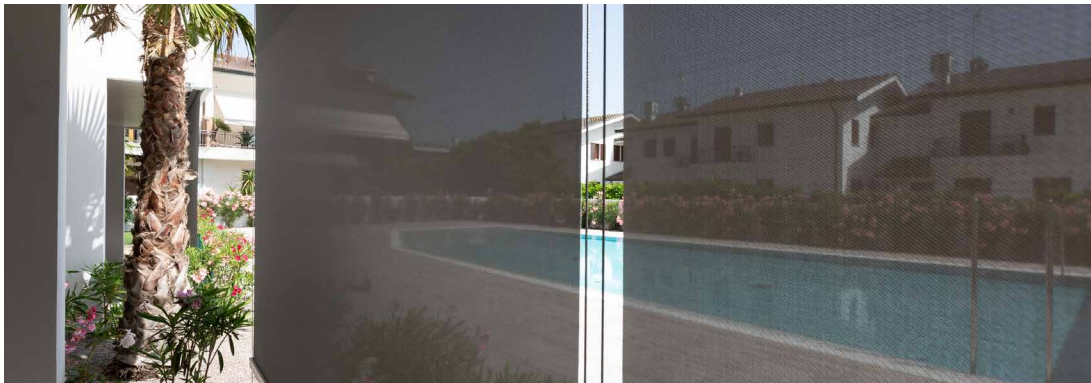

KE

Thermal comfort blends perfectly with beautiful style thanks to the more than 500 high performance fabrics available. A wide variety of colors, styles and solar shading factors allow for a system that meets your specific needs. All fabrics are CE Certified according to the EN 13561 and EN 14501 technical standards.

N.B.
See the Fabric Guide for further fabric specifications.

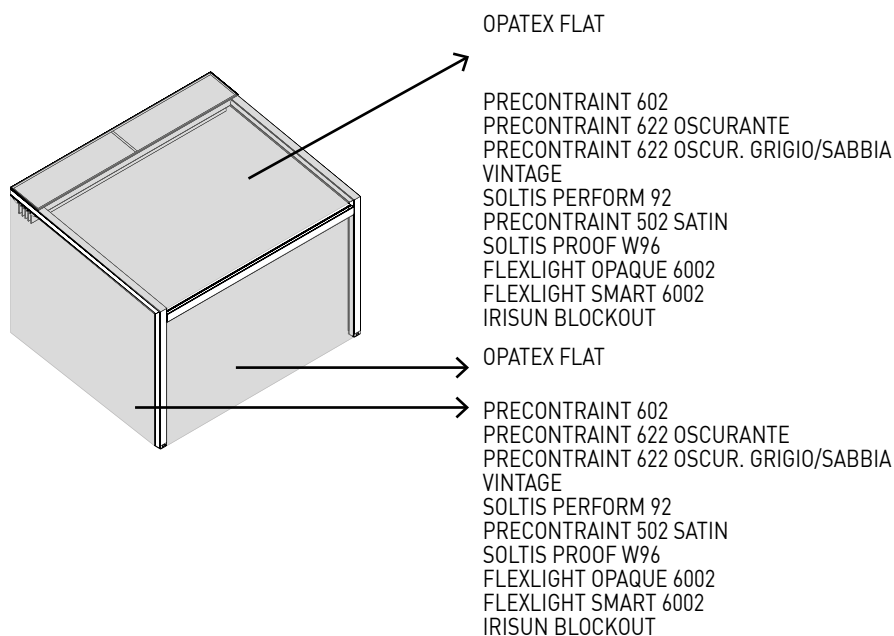

Standard

- OPATEX FLAT

Optional

- PRECONTRAIT 602
PRECONTRAIT 622 OSCURANTE
PRECONTRAIT 622 OSCUR. GRIGIO/SABBIA
VINTAGE
SOLTIS PERFORM 92
PRECONTRAIT 502 SATIN
SOLTIS PROOF W96
FLEXLIGHT OPAQUE 6002
FLEXLIGHT SMART 6002
IRISUN BLOCKOUT

DICHIARAZIONE DI PRESTAZIONE
008-10/2017

Codice identificazione prodotto: GENNIUS A100 LUX

Uso previsto del prodotto da costruzione, conformemente a UNI EN 13561:2015 - EN 1932:2013:
Tende per uso esterno

Nome e indirizzo del fabbricante:
KE PROTEZIONI SOLARI S.r.l.
Via Calnova, 160/a
30020 NOVENTA DI PIAVE (VE) -ITALY

Sistema di valutazione e verifica della costanza della prestazione del prodotto da costruzione:
Sistema 4

Specifica armonizzata:
UNI EN 13561:2015 - UNI EN 1932:2013

Classificazione secondo Prospetto 1 - § 4.1 UNI EN 13561:2015:

Classi di resistenza al vento	0	1	2	3	4	5	6
Pressione nominale del vento p_N (N/m ²)	<40	40	70	110	170	270	400
Pressione di sicurezza del vento p_S (N/m ²)	<48	48	84	132	204	234	480

Velocità massima del vento al di sopra della quale la tenda deve essere ritratta:

Classi di resistenza al vento	0	1	2	3	4	5	6
Velocità del vento (km/h)	<25	25	35	45	55	65	80

Prestazione dichiarata:

Resistenza ai carichi da vento – Configurazione a 2 guide							
		Larghezza (cm)					
		250	300	350	400	450	500
Sporgenza (cm)	250	6	6	6	6	6	6
	300	6	6	6	6	6	6
	350	6	6	6	6	6	6
	400	6	6	6	6	6	6
	450	6	6	6	6	6	5
	500	6	6	6	5	5	5
	550	6	6	5	5	5	-
600	6	5	5	4	4	-	

Resistenza ai carichi da vento – Configurazione a 3 guide										
		Larghezza (cm)								
		500	550	600	650	700	750	800	850	900
Sporgenza (cm)	250	6	6	6	6	6	6	6	6	6
	300	6	6	6	6	6	6	6	6	6
	350	6	6	6	6	6	6	5	5	5
	400	6	6	6	5	5	5	5	5	4
	450	5	5	5	5	4	4	4	4	4
	500	5	5	4	4	4	4	4	4	3
	550	4	4	4	4	4	-	-	-	-

Resistenza ai carichi da vento – Configurazione a 4 guide									
		Larghezza (cm)							
		950	1000	1050	1100	1150	1200	1250	1300
Sporgenza (cm)	250	6	6	6	6	6	6	6	6
	300	6	6	6	6	6	6	6	6
	350	6	6	6	6	6	5	5	5
	400	5	5	5	5	5	5	5	5
	450	5	5	4	4	4	4	4	4
	500	4	4	4	4	4	4	4	3
	550	4	4	4	3	3	-	-	-

Trasmittanza totale di energia solare g_{tot} : valore come riportato in etichetta CE.

La prestazione dei prodotti sopra indicati sono conformi all'insieme delle prestazioni dichiarate.
Si rilascia la presente dichiarazione di prestazione sotto la responsabilità esclusiva del fabbricante sopra identificato.

Noventa di Piave, 02 Gennaio 2017

Simone Mazzon
Amministratore delegato





Lighting plays a very important role in allowing our pergolas to be used at any time of day. KE uses LED lights, perfectly integrated into the profiles of the structures. LED technology allows for low energy consumption, multiple applications and changes to light color and intensity using a simple remote control.

N.B.
See the Fabric Guide for further fabric specifications.



DATI_TECNICI:

STRIP LED	
Watt	10W
volt	24V
flow	830lm
Color temperature	3400 K
LED/m	98 led/m



EN ISO 9001 _ Quality

KE has adopted a Quality Management System compliant with EN ISO 9001 requirements in order to maintain and increase quality and meet the highest customer expectations. This continuous improvement, through the control of all processes and careful evaluation of risks and opportunities, engages the entire organization in the development of systems to ensure the safety and reliability of the product and in the search for innovative solutions and technologies.

OHSAS 18001 _ Safety

KE has activated a Safety Management System as an integral part of its work organization, committing itself to organizing the entire structure in order to pursue the objectives of continuous improvement in terms of safety and health protection. Training, knowledge and compliance with current legislation on health and safety at work, cooperation and collaboration and preventive activities are actively pursued in order to minimize the possibility of non-compliance.

EN ISO 14001 _ Environment

KE is ISO 14001 certified for environmental management and strives to be an example of respect for environmental resources and for the continuous improvement of its environmental management system. It is committed to continuous improvement and pollution prevention in compliance with applicable laws, regulations and standards; systematically detects any environmental impact of manufacturing processes, promotes the culture of recovery and recycling in the company and in the related production chain.

CE MARK _ EN 13561

The CE marking of outdoor awnings is a signal to the Consumer that the product can be sold freely in the EU single market, as it complies with Community provisions which recognize safety as the priority of every product that has this agreed upon reference standard. Verification of wind resistance capacity and the clear indication of the ability of the awning to contribute to the energy savings of the building (Gtot), are some of the commitments that the manufacturer makes to a product that has earned the CE marking. The name of the manufacturer, the reference standard (in our case EN 13561) accompany a product that is properly adapted to European indications.

CE MARK _ EN 1090-1

KE extended the CE marking in 2015 to stationary awnings, which are among the aluminum structural components covered by the international standard EN 1090-1. This marking reflects our use of rigorous structural design and manufacturing with qualified processes, adequate industrial resources and qualified personnel.

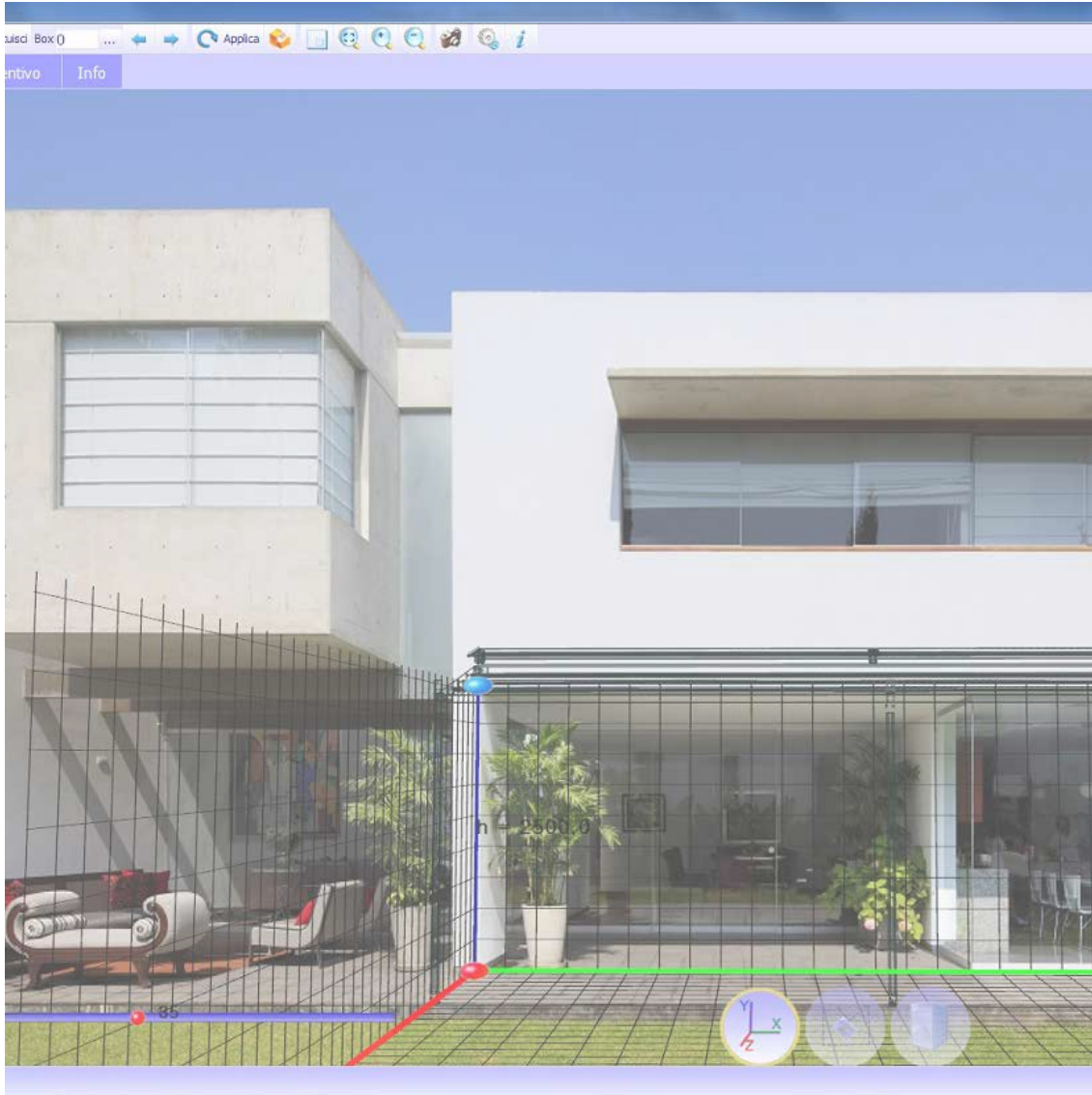

The KE B2B order system is a simple and intuitive service for placing orders conveniently online. An attractive graphic design, numerous functionalities and an easy and intuitive use mode that allows to access in real time to all the information related to the history of the orders and to the processing of the current ones. With the Cad Lite 3D Configurator you can configure Gennius and Bioclimatica models thanks to a constantly updated online catalogue. Thanks to an easy-to-use interface, it also allows you to formulate a complete quote with minimal error.

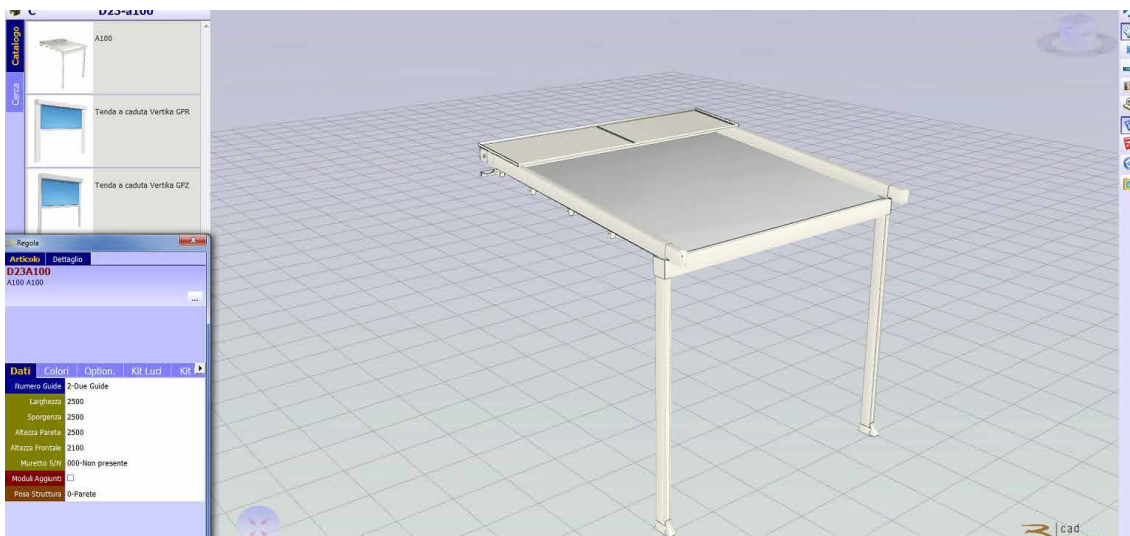

Home > Ambienti

Ambienti

La nostra missione è creare nuovi spazi outdoor da vivere in totale armonia. Grazie alle nostre **coperture solari e alle strutture per esterni personalizzate, potrai arredare con stile il tuo terrazzo, giardino, attico, ma anche modulare...** [Leggi di più](#)



BIM technology improves the working method of designers and is now the main source of information for the realisation of a project. With BIM the model is generated in a "parametric 3D" from which a series of information such as 2D views, elevations, sections but also metric calculations and much more can be automatically derived. On the KE website you can find the BIM gallery of the main KE models, the certifications and all the useful technical documentation for each product: www.keoutdoordesign.com

Area Clienti IT-IT

Referenze Area Media

Brochure e Cataloghi
BIM & 3D Models
Blog
News
Video

POWERED BY SYNCRONIA

KE SCREENY 85 - SINGLE UNIT VERSION	KE SCREENY BOX	KE SPACE	KE VENEZIA GOLD	Kedry Skyllife	KE SCREENY 85 - SINGLE UNIT VERSION

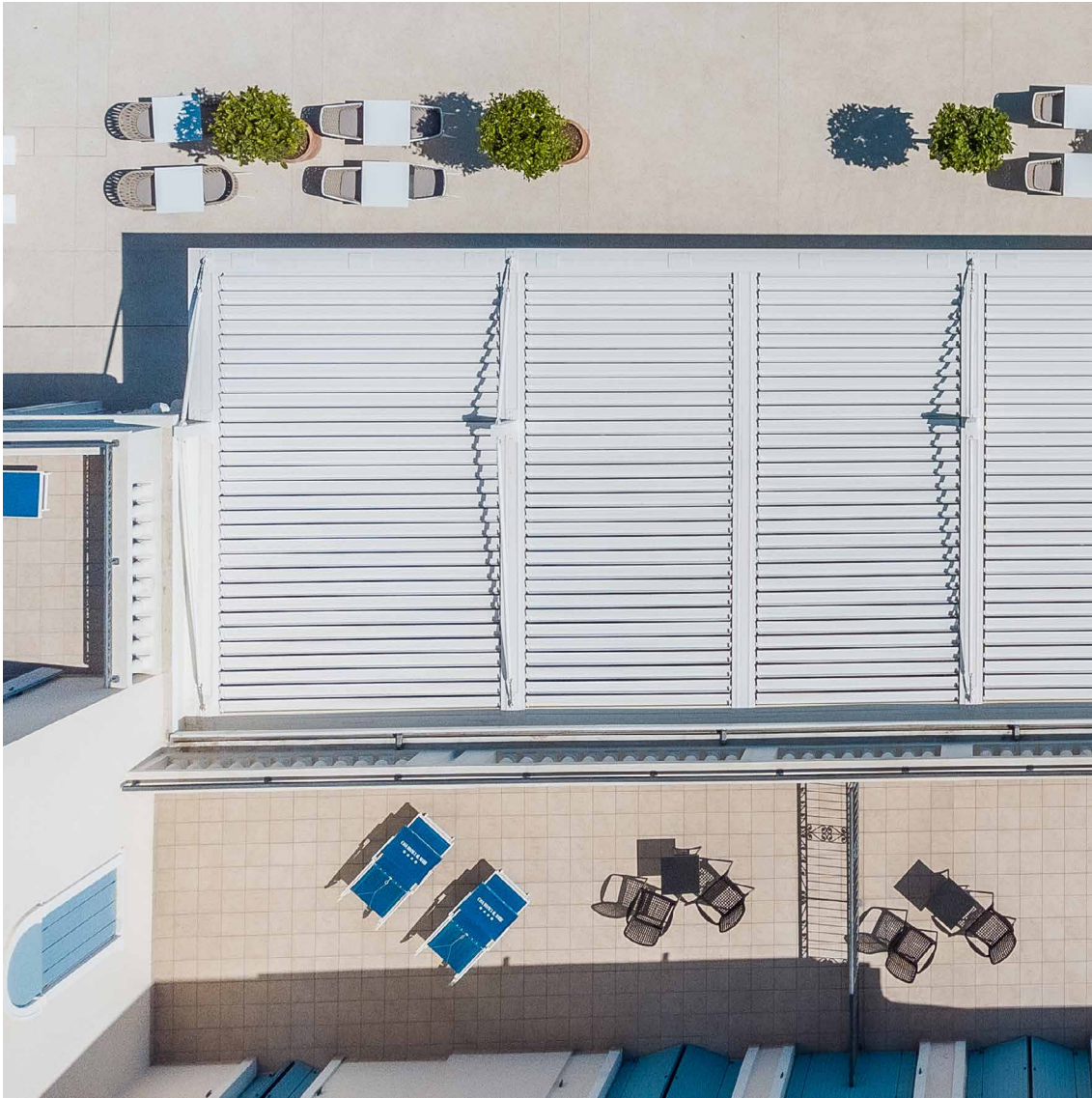

**A GROUP,
A VISION,
A GROUP IN EVOLUTION**

Since 1987, KE has been designing and manufacturing arm awnings, cassette awnings, drop awnings, canopies, shelters and is specialised in shading structures that enhance the liveability of outdoor spaces, up to the redesign and restyling of urban furniture. Both for the variety of the range and the depth of the configurations, KE is a manufacturing reality able to satisfy the most demanding requests the most demanding requirements of designers, architects, window and door manufacturers, upholsterers and outdoor professionals.

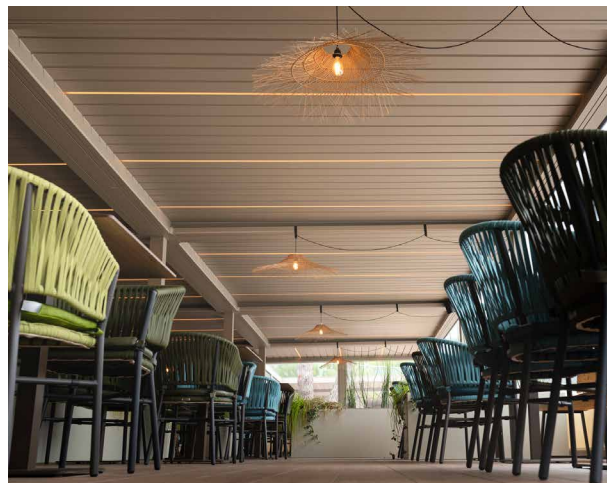

Improving the experience

With KE's professionalism and experience you can rely on quality products designed to enhance your customers' outdoor experience. With KE it will be easier to live the outdoor space in perfect harmony with the surrounding environment, widening the viewpoints and ensuring maximum comfort in all seasons.