

T1

22.04.24_rev.01



KE
ENJOY THE OUTDOORS





↔ 1300 ↻ 800



↔ 150 ↻ 100

Horizontal folding awning with trolleys and guides.

The maximum dimensions allowed are 1300x80. 104 mq coverage area.

The profiles are made of EN AW-6060 extruded aluminium alloy (with 5.5x10 cm guides).

It can be recess or ceiling-mounted using steel L-shaped brackets and hardware.

The painting of the interested parties is carried out with epoxy powders based on polyester resin.

The standard colors are RAL 9010 White, RAL 1013 Off-white, RAL 7016 Iron, RAL 1013 matt Off white, RAL 8014 matt Classic brown, rough Carbon and rough Corten.

Opatex Flat are the fabrics available as standard.

Additional options include other RAL colors and KE fabric in the samples, motorised or winch movement (up to 3 m overhang on single module).

It is possible to install lighting on the guide and the installation of light sensors and anemometers with the possibility of remote management through connection devices.

Wind resistance guaranteed up to class 6 (EN 13561:2015).

Wind-resistant up to Class 6 (EN 13561:2015).

Product certified with CE marking according to EN 13561:2015

OPTIONAL

LIGHT



TECHNICAL INFORMATION

General technical plan

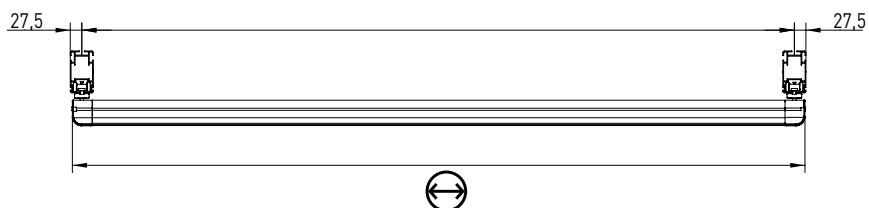
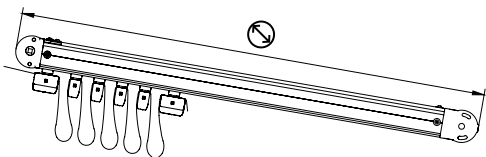

Profiles dimensions

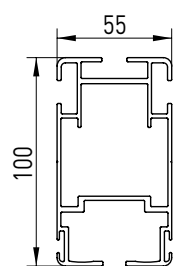

Guide

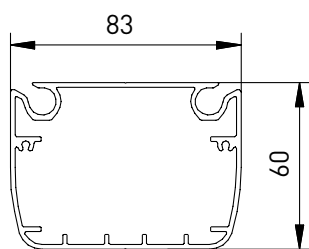

Terminal bar profile

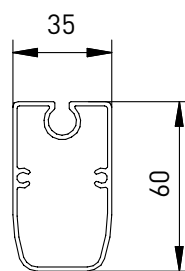

Fabric carrying Crossbar profile

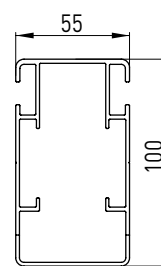

Crossbar profile

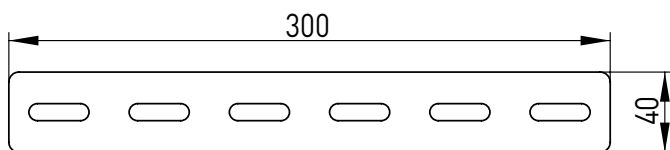

Brackets for inclination

Guide support dimensions

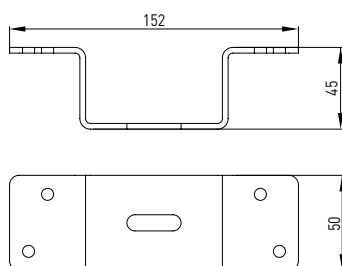
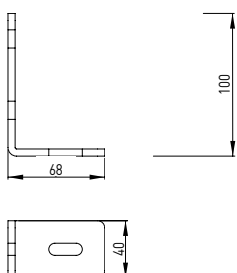

TECHNICAL INFORMATION

Motorized control

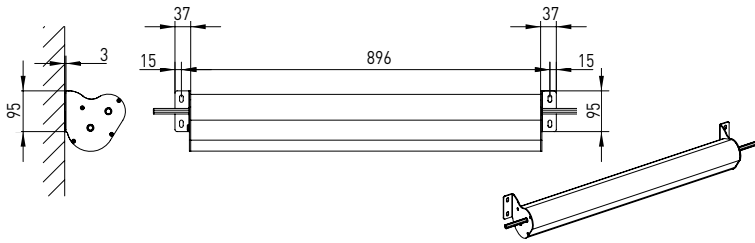

Manual control

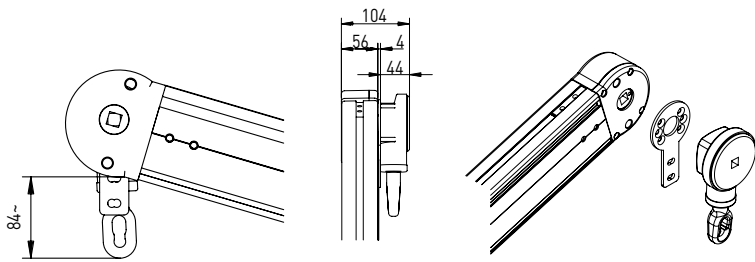

Pulley bracket

Guides connection

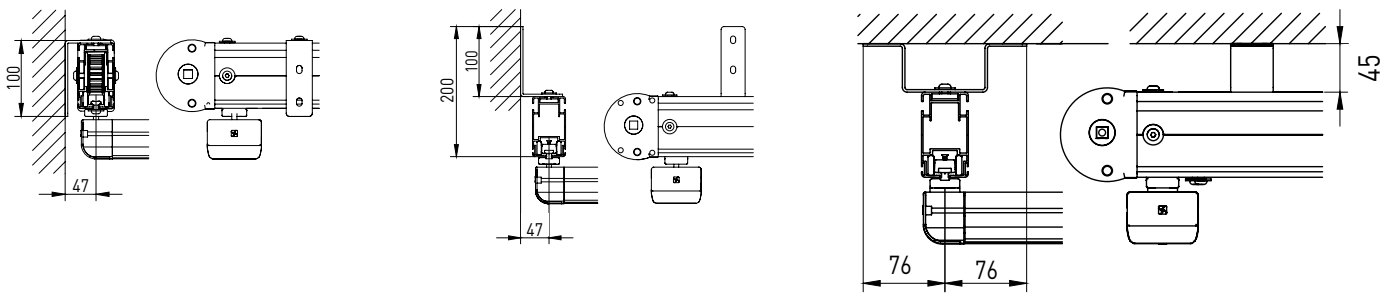

Wall

Ceiling

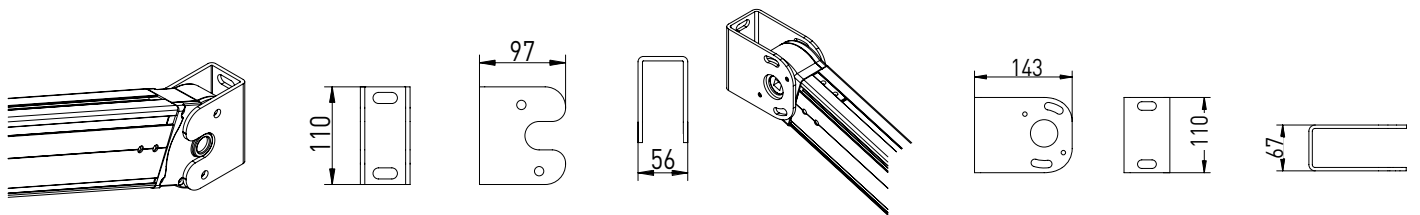

Front reference bracket

A1 Wall Bracket

TECHNICAL INFORMATION

Cloth dimensions

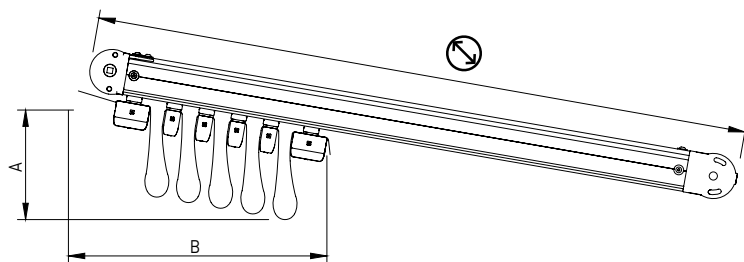

Indicative values of the fabric encumbrance and the number of the fabric carrying crossbar profiles.
Attention: the values shown may vary according to the slope.

Traverse movement

	A cm	B cm	N
250	34	44	5
300	37	44	5
350	39	49	6
400	39	54	7
450	39	60	8
500	39	65	9
550	40	70	10
600	43	70	10
650	43	75	11
700	45	75	12
750	45	80	12
800	47	85	13

Crossbar profile numbers (terminals included). Maximum interaxis fabric carrying cross bar profiles measure cm 58.

TECHNICAL INFORMATION

SLOPES

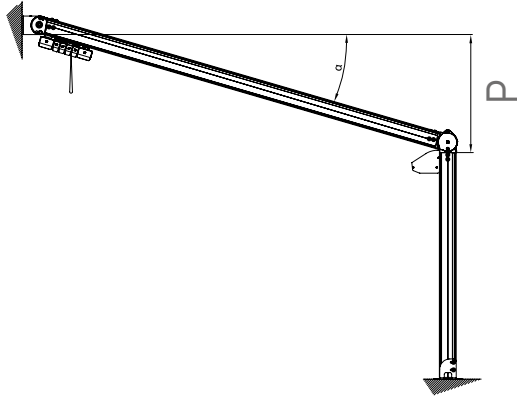

2 GUIDES	cm	Projection					
		250	300	350	400	450	500
		STD /	STD /	STD /	STD /	STD /	STD /
	150	12 /	14 /	16 /	18 / 11	20 / 12	24 / 13
	200	16 /	19 /	22 /	24 / 15	27 / 17	32 / 18
	250	20 /	24 /	27 /	31 / 20	34 / 21	40 / 23
	300	25 /	29 /	33 /	38 / 24	42 / 26	49 / 28
	350	29 /	34 /	39 /	44 / 29	49 / 31	59 / 33
	400	34 /	40 /	45 /	51 / 33	57 / 36	68 / 38
	450	39 /	45 /	52 /	58 / 38	65 / 41	79 / 44
	500	44 /	51 /	58 /	65 / 43	72 / 47	89 / 50
	550	49 /	57 /	65 /	73 / 48	80 / 52	98 / 56
	600	55 /	63 /	71 /	80 / 53	89 / 58	108 / 62
	650	60 /	69 /	78 /	88 / 58	97 / 64	
	700	66 /	75 /	85 /	95 / 64	105 / 70	
	750	71 /	82 /	92 /	103 / 69	114 / 76	
	800	77 /	88 /	100 /	111 / 75	122 / 83	

Projection

Width

STD
Standard

| |
Added module

P= Minimum inclination for a correct water outflow

3 GUIDES	cm	Projection									
		500	550	600	650	700	750	800	850	900	
		STD /	STD /	STD /	STD /	STD /	STD /	STD /	STD /	STD /	
	150	13 /	15 /	16 / 11	17 / 12	18 / 13	20 / 13	21 / 14	22 / 15	23 / 16	
	200	18 /	20 /	21 / 15	23 / 16	25 / 17	26 / 18	28 / 19	30 / 20	31 / 21	
	250	23 /	25 /	27 / 19	29 / 21	31 / 22	33 / 23	35 / 24	37 / 25	39 / 27	
	300	28 /	31 /	33 / 24	35 / 25	38 / 27	40 / 28	42 / 29	45 / 31	47 / 32	
	350	33 /	36 /	39 / 28	42 / 30	44 / 31	47 / 33	50 / 35	53 / 37	56 / 38	
	400	39 /	42 /	45 / 33	48 / 35	51 / 37	54 / 38	58 / 40	61 / 42	64 / 44	
	450	44 /	48 /	51 / 37	55 / 40	58 / 42	62 / 44	65 / 46	69 / 48	72 / 51	
	500	50 /	54 /	58 / 42	62 / 45	65 / 47	69 / 49	73 / 52	77 / 54	81 / 57	
	550	56 /	60 /	64 / 47	68 / 50	73 / 52	77 / 55	81 / 58	85 / 61	89 / 63	
	600	62 /	66 /	71 / 52	75 / 55	80 / 58	84 / 61	89 / 64	94 / 67	98 / 70	
	650	68 /	73 /	78 / 57	83 / 60	87 / 64	92 / 67	97 / 70	102 / 74	107 / 77	
	700	74 /	80 /	85 / 63	90 / 66	95 / 70	100 / 73	105 / 77	111 / 80	116 / 84	
	750	81 /	86 /	92 / 68	97 / 72	103 / 76	108 / 79	114 / 83	119 / 87	125 / 91	
	800	88 /	93 /	99 / 74	105 / 78	111 / 82	116 / 86	122 / 90	128 / 94	134 / 98	

4 GUIDES	cm	Projection							
		950	1000	1050	1100	1150	1200	1250	1300
		STD /	STD /	STD /	STD /	STD /	STD /	STD /	STD /
	150	16 / 13	17 / 13	17 / 14	18 / 14	19 / 15	20 / 15	21 / 16	21 / 17
	200	21 / 17	22 / 18	23 / 19	25 / 19	26 / 20	27 / 21	28 / 22	29 / 22
	250	27 / 22	28 / 23	30 / 24	31 / 25	32 / 26	34 / 27	35 / 28	36 / 28
	300	33 / 26	35 / 28	36 / 29	38 / 30	39 / 31	41 / 32	42 / 34	44 / 35
	350	39 / 31	41 / 33	43 / 34	45 / 36	46 / 37	48 / 38	50 / 40	52 / 41
	400	45 / 36	47 / 38	49 / 40	51 / 41	54 / 43	56 / 44	58 / 46	60 / 48
	450	52 / 42	54 / 43	56 / 45	59 / 47	61 / 49	63 / 51	66 / 53	68 / 54
	500	58 / 47	61 / 49	63 / 51	66 / 53	68 / 55	71 / 57	74 / 59	76 / 61
	550	65 / 52	68 / 55	70 / 57	73 / 59	76 / 62	79 / 64	82 / 66	85 / 69
	600	71 / 58	75 / 60	78 / 63	81 / 65	84 / 68	87 / 71	90 / 73	94 / 76
	650	78 / 63	82 / 66	85 / 69	89 / 72	92 / 75	95 / 78	99 / 80	102 / 83
	700	85 / 69	89 / 72	93 / 75	96 / 79	100 / 82	104 / 85	108 / 88	111 / 91
	750	93 / 75	97 / 79	101 / 82	104 / 85	108 / 89	112 / 92	116 / 95	120 / 99
	800	100 / 81	104 / 85	108 / 89	113 / 92	117 / 96	121 / 99	125 / 103	130 / 107



The KE painting process includes high quality standards, with an 8-stage pre-treatment that includes degreasing, deoxidation, and protective treatments before painting. Thanks to this last phase, components and profiles are further guaranteed against particularly severe environmental situations. At the end of the process the profiles and components are painted with polyester resin-based epoxy powders.

Treated components are periodically tested in salt spray according to the ISO 9227 standard to confirm conformity and consistency of the process.

The European product standard EN 13561: 2015 defines corrosion resistance classes of the metal parts that make up the product according to the table below.

Tests performed on the painted components and profiles allow us to classify the product in the maximum class achievable according to EN 13561: 2015, C2 / 4 (48 h - internal components, 240 h - external components).

Equipped with the most modern process control systems including continuous monitoring in which the working parameters are recorded and corrected every 2 minutes, the new painting process guarantees the high quality characteristics of the product while minimizing the risk of environmental pollution.

This is a choice born from the desire to always keep up with technology while guaranteeing operator safety and low environmental impact.

Thanks to nanotechnologies, the implemented coating constitutes an excellent base for anchoring paints, ensuring excellent adhesion and resisting corrosion.

The plant in which aluminum or galvanized steel products with a length of up to 7 meters can be treated, includes 7 treatment tanks, 1 double compartment drying oven, 1 polymerization oven and 1 purification plant for waste water treatment.

The real focus of the plant, however, is the two powder coating booths, each with 4 stations for manual retouching. The booths allow greater production continuity, thanks to a drastic reduction in required stops for color changes.

CORROSION RESISTANCE

Classes	1	2	3	4
Internal components	24	48		
External components		48	96	240

COLOURS



When working with color, we know that our whole world is defined by light. And color is nothing more than a breakdown of light. Objects reflect back to our eyes only the color that defines it. This is why it is so important to recognize the close link between color and matter. For this project, there are three keywords that guide the research: Words, Places, Matters.

WORDS: Naming colors is important to make them familiar and easily recognizable.

PLACES: Places define colors. Recognizing different types of places is a starting point for defining and suggesting color combinations.

MATERIALS: Objects do not exist in isolation, but rather match the environment around them: analyzing the materials that make up the environment itself helps us to make decisions; to decide, for example, if the character of a place is false or if instead it is genuinely artistic.

COLOURS RAL



● Ral standard (without supplement)

SPECIAL STRUCTURES

The technical office is available for assistance with non-standard structures such as some examples shown below. KE can also produce special brackets on request.

Cantilevered

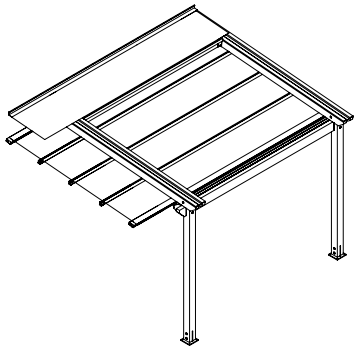

Cantilevered with recess

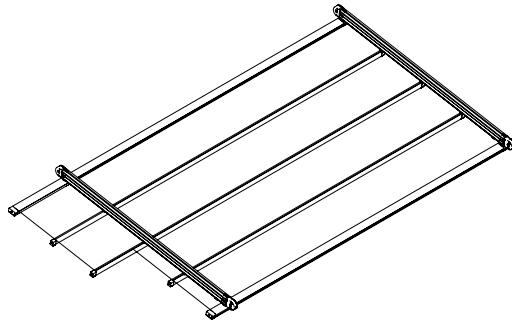

Cantilevered with recess

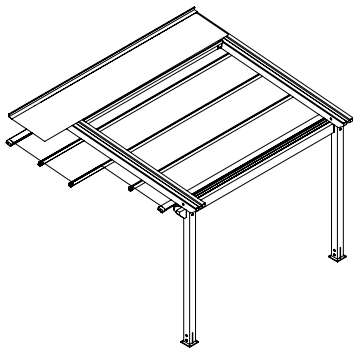

Slanting

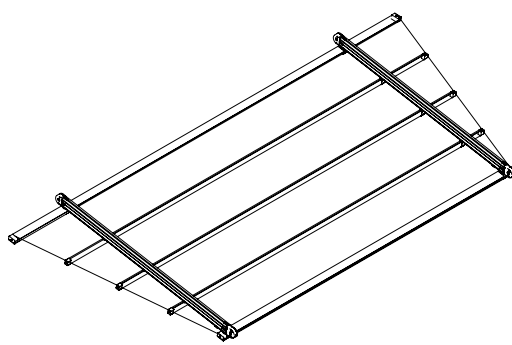

Slanting

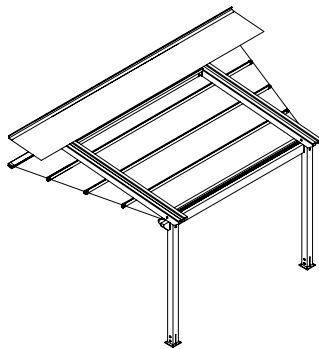

Cantilevered

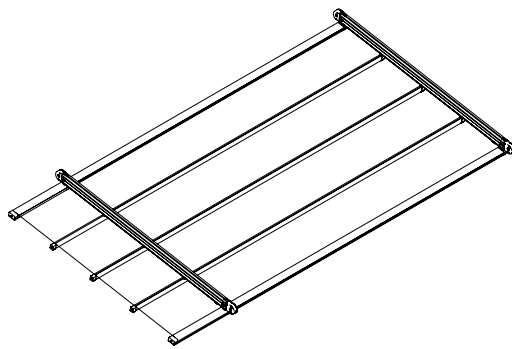

FABRICS



KE
ENJOY THE OUTDOORS

Thermal comfort blends perfectly with beautiful style thanks to the more than 500 high performance fabrics available. A wide variety of colors, styles and solar shading factors allow for a system that meets your specific needs. All fabrics are CE Certified according to the EN 13561 and EN 14501 technical standards.

N.B.
See the Fabric Guide for further fabric specifications.

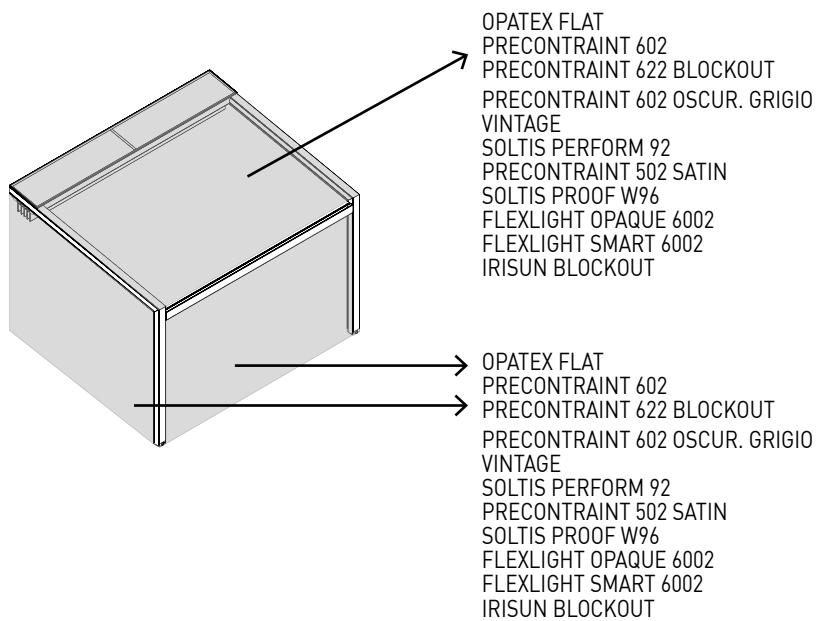

Standard

- OPATEX FLAT

Optional

PRECONSTRAINT 602
PRECONSTRAINT 622 OSCURANTE
PRECONSTRAINT 602 OSCUR. GRIGIO
VINTAGE
SOLTIS PERFORM 92
PRECONSTRAINT 502 SATIN
SOLTIS PROOF W96
FLEXLIGHT OPAQUE 6002
FLEXLIGHT SMART 6002
IRISUN BLOCKOUT

DICHIARAZIONE DI PRESTAZIONE
008-04/2017

Codice identificazione prodotto: **GENNIUS T1**

Uso previsto del prodotto da costruzione, conformemente a UNI EN 13561:2015 - EN 1932:2013:
Tende per uso esterno

Nome e indirizzo del fabbricante:
KE PROTEZIONI SOLARI S.r.l.
Via Calnova, 160/a
30020 NOVENTA DI PIAVE (VE) - ITALY

Sistema di valutazione e verifica della costanza della prestazione del prodotto da costruzione: **Sistema 4**

Specifica armonizzata:
UNI EN 13561:2015 - UNI EN 1932:2013

Classificazione secondo Prospetto 1 - § 4.1 UNI EN 13561:2015:

Classi di resistenza al vento	0	1	2	3	4	5	6
Pressione nominale del vento p_n (N/m ²)	<40	40	70	110	170	270	400
Pressione di sicurezza del vento p_s (N/m ²)	<48	48	84	132	204	234	480

Velocità massima del vento al di sopra della quale la tenda deve essere ritratta:

Classi di resistenza al vento	0	1	2	3	4	5	6
Velocità del vento (km/h)	<25	25	35	45	55	65	80

Prestazione dichiarata:

Resistenza ai carichi da vento - Configurazione a 2 guide							
		Larghezza (cm)					
		250	300	350	400	450	500
Sporgenza (cm)	250	6	6	6	6	6	5
	300	6	6	6	6	6	5
	350	6	6	6	6	6	5
	400	6	6	6	6	6	5
	450	6	6	6	6	6	5
	500	6	6	6	6	6	5
	550	6	6	6	6	6	-
	600	6	6	6	6	6	-
	650	6	6	6	6	6	-
	700	6	6	6	6	6	-
750	6	6	6	6	6	-	
800	6	6	6	6	6	-	

Resistenza ai carichi da vento - Configurazione a 3 guide										
		Larghezza (cm)								
		500	550	600	650	700	750	800	850	900
Sporgenza (cm)	250	6	6	6	6	6	6	6	6	6
	300	6	6	6	6	6	6	6	6	6
	350	6	6	6	6	6	6	6	6	6
	400	6	6	6	6	6	6	6	6	6
	450	6	6	6	6	6	6	6	6	6
	500	6	6	6	6	6	6	6	6	6
	550	6	6	6	6	6	6	6	6	6
	600	6	6	6	6	6	6	6	6	6
	650	6	6	6	6	6	6	6	6	6
	700	6	6	6	6	6	6	6	6	6
750	6	6	6	6	6	6	6	6	6	
800	6	6	6	6	6	6	6	6	6	

Resistenza ai carichi da vento - Configurazione a 4 guide									
		Larghezza (cm)							
		950	1000	1050	1100	1150	1200	1250	1300
Sporgenza (cm)	250	6	6	6	6	6	6	6	6
	300	6	6	6	6	6	6	6	6
	350	6	6	6	6	6	6	6	6
	400	6	6	6	6	6	6	6	6
	450	6	6	6	6	6	6	6	6
	500	6	6	6	6	6	6	6	6
	550	6	6	6	6	6	6	6	6
	600	6	6	6	6	6	6	6	6
	650	6	6	6	6	6	6	6	6
	700	6	6	6	6	6	6	6	6
750	6	6	6	6	6	6	6	6	
800	6	6	6	6	6	6	6	6	

Trasparenza totale di energia solare g_{tot} : valore come riportato in etichetta CE.

La prestazione dei prodotti sopra indicati sono conformi all'insieme delle prestazioni dichiarate.
Si rilascia la presente dichiarazione di prestazione sotto la responsabilità esclusiva del fabbricante sopra identificato.

Noventa di Piave, 02 Gennaio

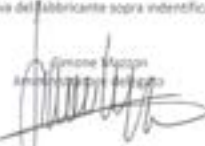
 Simone Magagnoli
 Amministratore Delegato

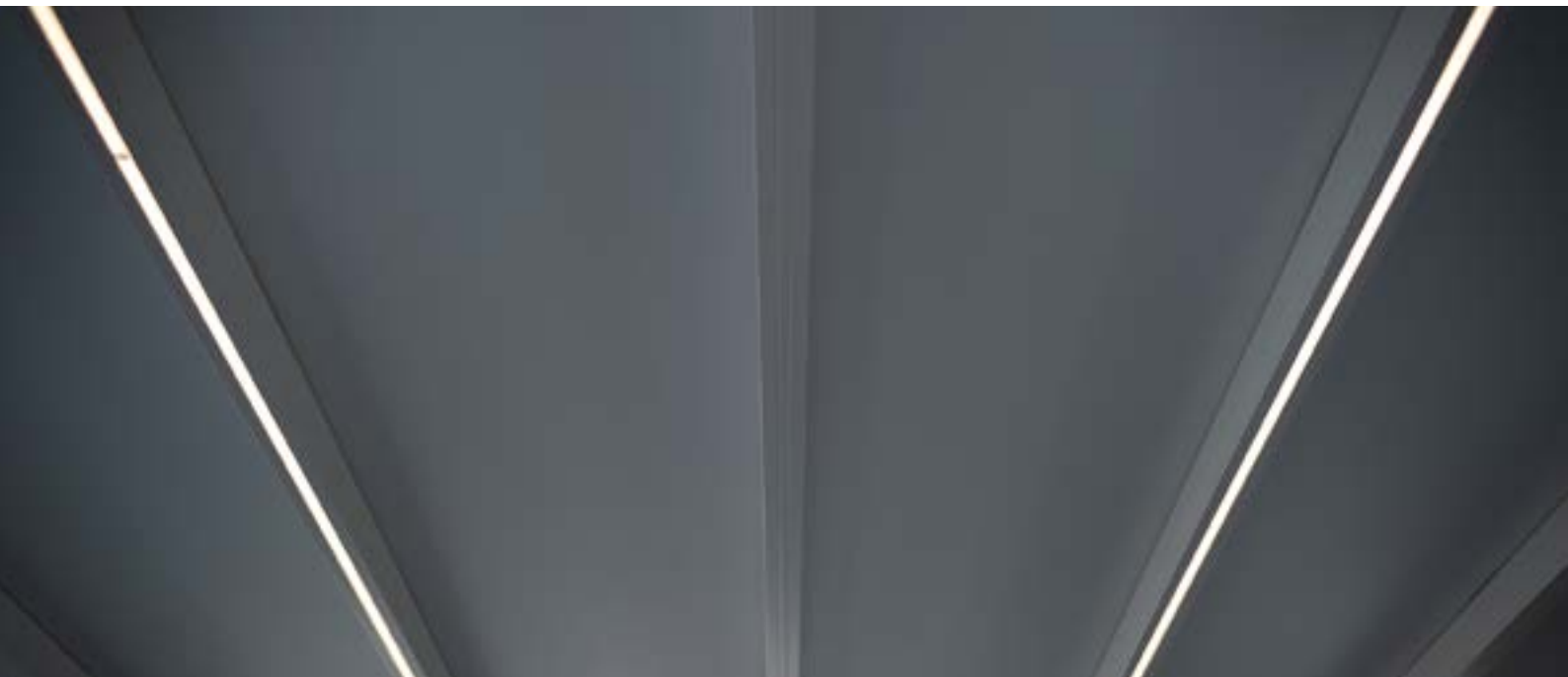

Lighting plays a very important role in allowing our pergolas to be used at any time of day. KE uses LED lights, perfectly integrated into the profiles of the structures. LED technology allows for low energy consumption, multiple applications and changes to light color and intensity using a simple remote control.

N.B.
See the Fabric Guide for further fabric specifications.



DATI_TECNICI:

STRIP LED	
Watt	10W
volt	24V
flow	830lm
Color temperature	3400 K
LED/m	98 led/m



EN ISO 9001

KE has adopted a Quality Management System compliant with EN ISO 9001 requirements in order to maintain and increase quality and meet the highest customer expectations. This continuous improvement, through the control of all processes and careful evaluation of risks and opportunities, engages the entire organization in the development of systems to ensure the safety and reliability of the product and in the search for innovative solutions and technologies.

OHSAS 18001

KE has activated a Safety Management System as an integral part of its work organization, committing itself to organizing the entire structure in order to pursue the objectives of continuous improvement in terms of safety and health protection. Training, knowledge and compliance with current legislation on health and safety at work, cooperation and collaboration and preventive activities are actively pursued in order to minimize the possibility of non-compliance.

EN ISO 14001

KE is ISO 14001 certified for environmental management and strives to be an example of respect for environmental resources and for the continuous improvement of its environmental management system. It is committed to continuous improvement and pollution prevention in compliance with applicable laws, regulations and standards; systematically detects any environmental impact of manufacturing processes, promotes the culture of recovery and recycling in the company and in the related production chain.

CE MARK _ EN 13561

The CE marking of outdoor awnings is a signal to the Consumer that the product can be sold freely in the EU single market, as it complies with Community provisions which recognize safety as the priority of every product that has this agreed upon reference standard. Verification of wind resistance capacity and the clear indication of the ability of the awning to contribute to the energy savings of the building (Gtot), are some of the commitments that the manufacturer makes to a product that has earned the CE marking. The name of the manufacturer, the reference standard (in our case EN 13561) accompany a product that is properly adapted to European indications.

CE MARK _ EN 1090-1

KE extended the CE marking in 2015 to stationary awnings, which are among the aluminum structural components covered by the international standard EN 1090-1. This marking reflects our use of rigorous structural design and manufacturing with qualified processes, adequate industrial resources and qualified personnel.

VIRTUAL SHOW ROOM



KE has adapted to the new ways of using the product by working on a digital showroom that is able to give the user a high-impact visual experience, a functional space where they can move around freely, receive detailed information on products with a simple click, and access content of interest quickly and intuitively. There is viewable content such as augmented reality and downloadable files such as data sheets, brochures and 3D models.



KE
ENJOY THE OUTDOORS

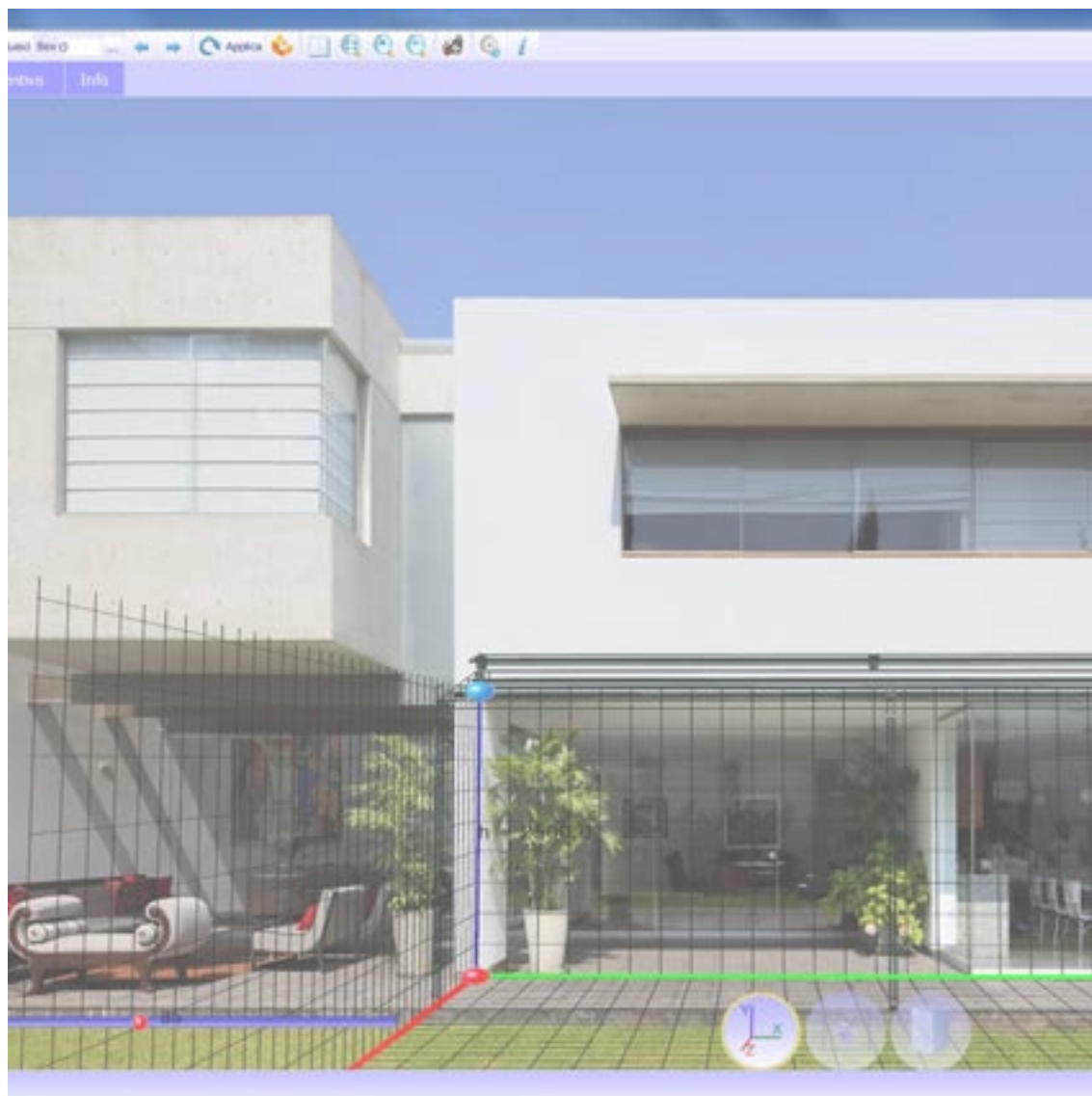

The KE B2B order system is a simple and intuitive service for placing orders conveniently online. An attractive graphic design, numerous functionalities and an easy and intuitive use mode that allows to access in real time to all the information related to the history of the orders and to the processing of the current ones. With the Cad Lite 3D Configurator you can configure Gennius and Bioclimatica models thanks to a constantly updated online catalogue. Thanks to an easy-to-use interface, it also allows you to formulate a complete quote with minimal error.

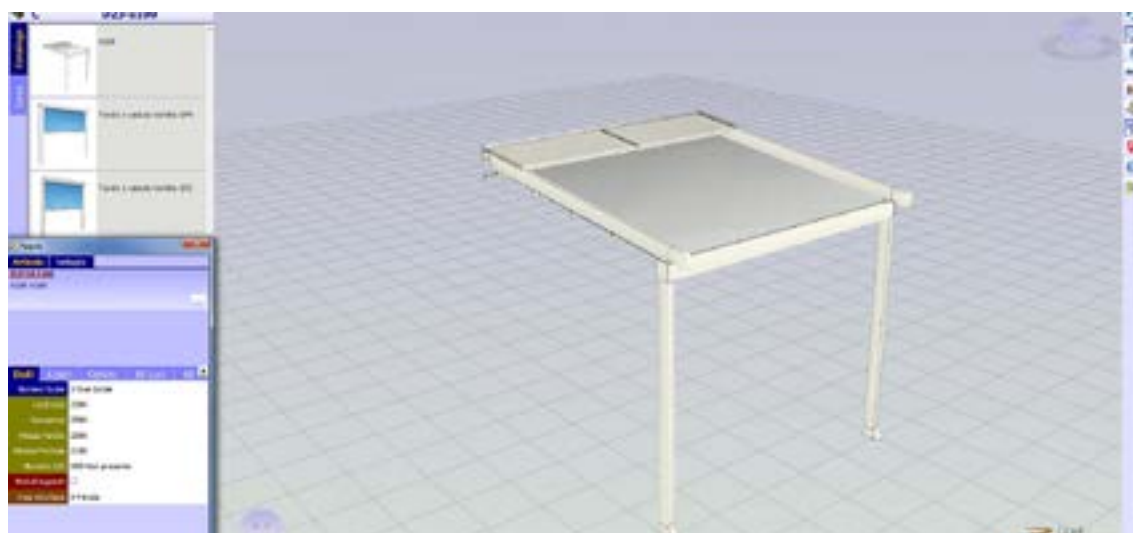

Home > Ambienti

Ambienti

La nostra missione è creare nuovi spazi outdoor da vivere in totale armonia. Grazie alle nostre coperture solari e alle strutture per esterni personalizzate, potrai arredare con stile il tuo terrazzo, giardino, attico, ma anche modulare. [Leggi di più](#)

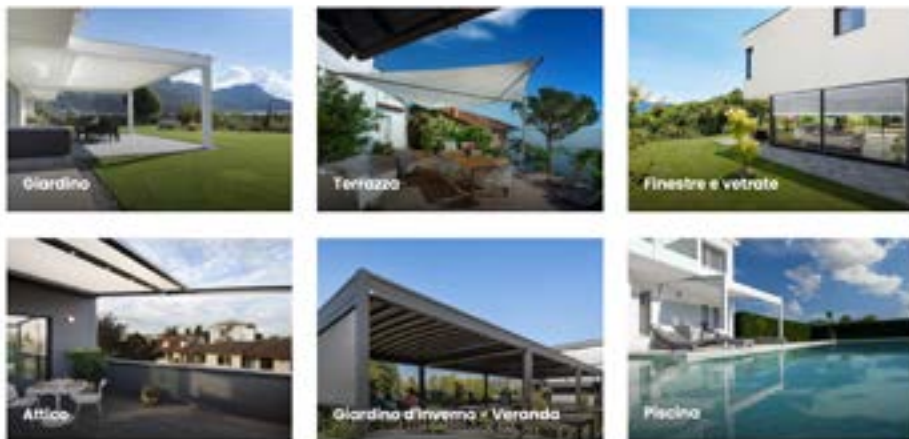

BIM technology improves the working method of designers and is now the main source of information for the realisation of a project. With BIM the model is generated in a "parametric 3D" from which a series of information such as 2D views, elevations, sections but also metric calculations and much more can be automatically derived. On the KE website you can find the BIM gallery of the main KE models, the certifications and all the useful technical documentation for each product: www.keoutdoordesign.com





A GROUP, A VISION, A GROUP IN EVOLUTION

Since 1987, KE has been designing and manufacturing arm awnings, cassette awnings, drop awnings, canopies, shelters and is specialised in shading structures that enhance the liveability of outdoor spaces, up to the redesign and restyling of urban furniture. Both for the variety of the range and the depth of the configurations, KE is a manufacturing reality able to satisfy the most demanding requests the most demanding requirements of designers, architects, window and door manufacturers, upholsterers and outdoor professionals.



Improving the experience

With KE's professionalism and experience you can rely on quality products designed to enhance your customers' outdoor experience. With KE it will be easier to live the outdoor space in perfect harmony with the surrounding environment, widening the viewpoints and ensuring maximum comfort in all seasons. all seasons.