

# A100 STAR

22.04.24\_rev.01



**KE**  
ENJOY THE OUTDOORS



# A100 STAR



↔ 1300/500 ↻ 500/600 ↔ 155 ↻ 100

Solar shading with cover sheet fixed on crossbars and foldable with horizontal packing, by means of trolleys and guides.

The maximum dimensions allowed are 1300x500 and 1150x550 with 260 cm. high pillars (6x11 pillars) and 300 cm. (11x11 pillars)

The profiles are made of EN AW-6060 extruded aluminium alloy (with 6x11 cm guides and columns).

The structure can be wall-mounted via steel brackets and hardware.

The painting of the interested parties is carried out with epoxy powders based on polyester resin.

The standard colors are RAL 9010 White, RAL 1013 Off-white, RAL 7016 Iron, rough Carbon and rough Corten.

Opatex Flat are the fabrics available as standard.

Additional options include other RAL colors and KE fabric in the samples, motorised or winch movement.

It is possible to install lighting on the guide and the installation of light sensors and anemometers with the possibility of remote management through connection devices.

Possibility of installing lateral closures and glazes.

Wind resistance guaranteed up to class 6 (EN 13561:2015).

GTOT solar shading class (EN 14501:2006) assigned to the fabric.

Product certified with CE marking according to EN 13561:2015

## OPTIONAL

LIGHT



GABLES

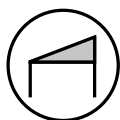

VERTIKA

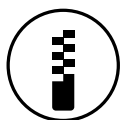

# TECHNICAL INFORMATION

## General technical plan

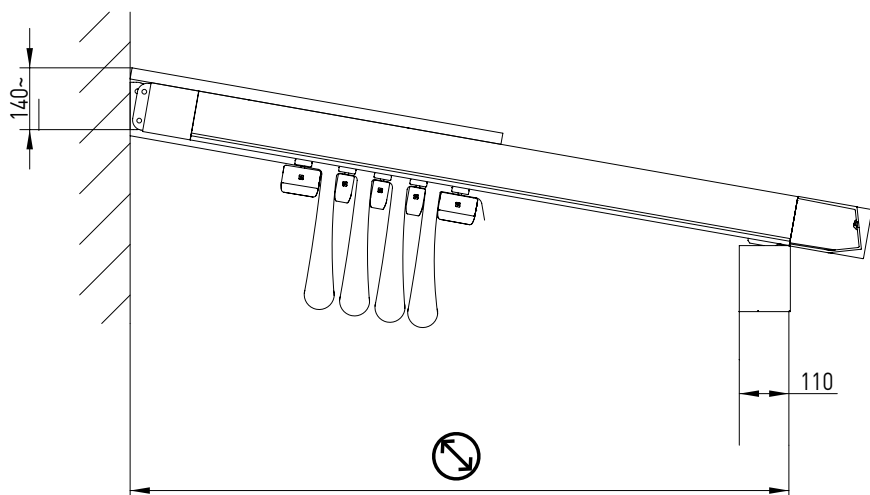

## Guides interaxis width

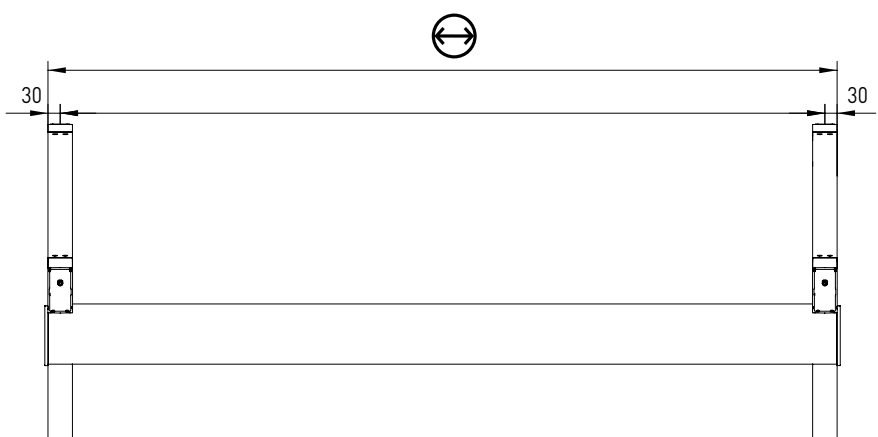

## Profiles dimensions

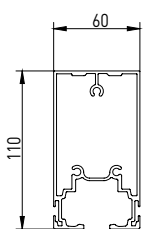

Guide

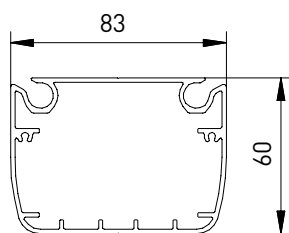

Terminal bar profile

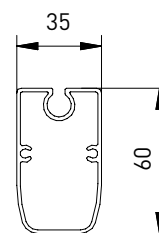

Fabric carrying Crossbar profile

# TECHNICAL INFORMATION

## Girder section

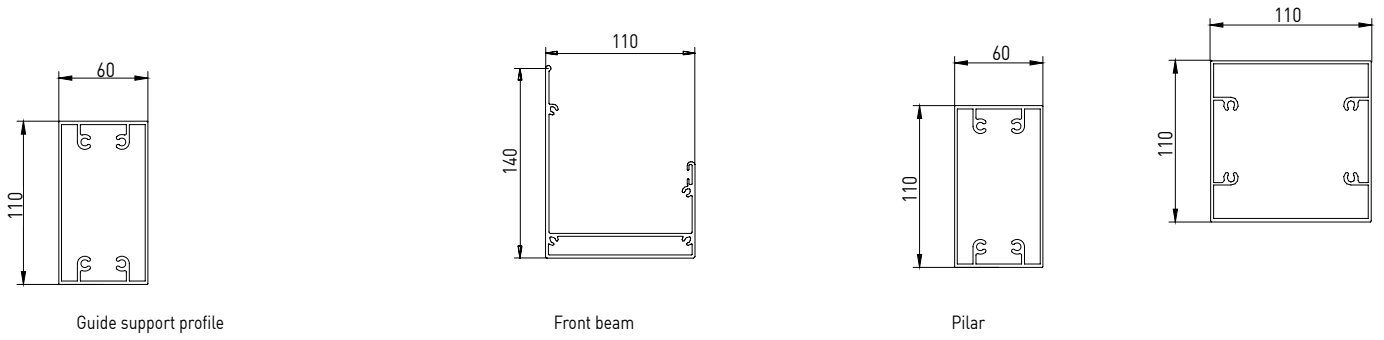

## Ground connection

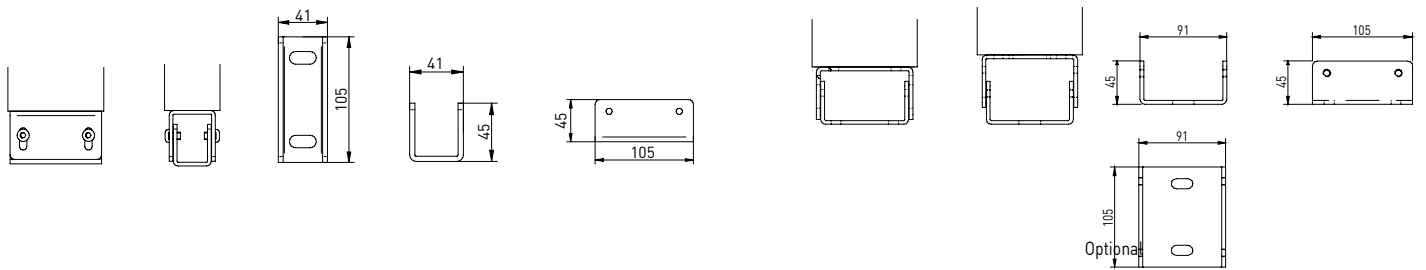

## Ceiling installation

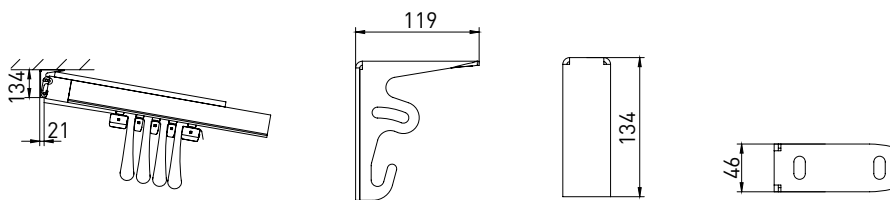

## Wall installation

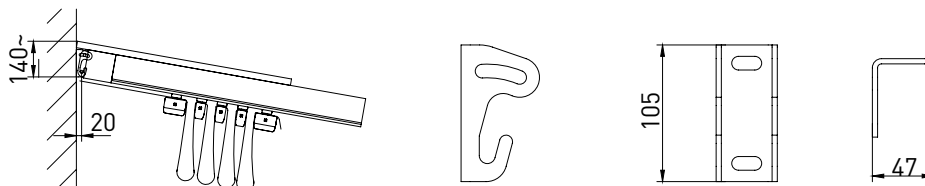

## TECHNICAL INFORMATION

### Cloth dimensions

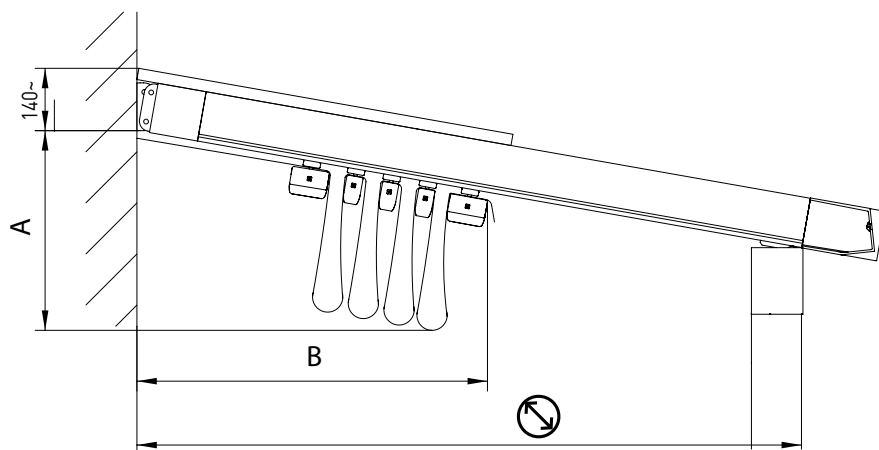

Indicative values of the fabric encumbrance and the number of the fabric carrying crossbar profiles.  
Attention: the values shown may vary according to the slope.

### Traverse movement

	A cm	B cm	N
250	39	50	5
300	40	55	5
350	41	60	6
400	42	66	7
450	43	71	8
500	44	71	9
550	45	76	10
600	45	81	10

Crossbar profile numbers (terminals included). Maximum interaxis fabric carrying cross bar profiles measure cm 58.

# TECHNICAL INFORMATION

## SLOPES

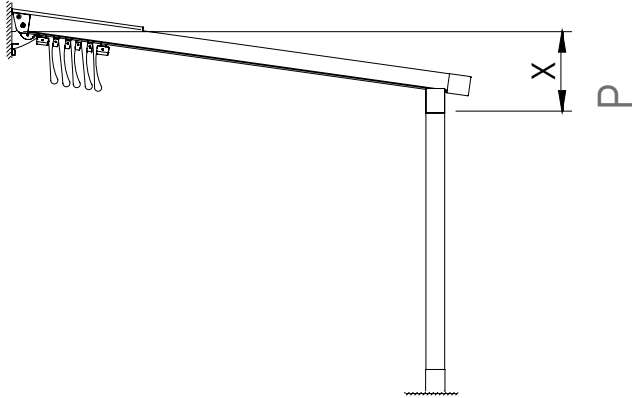

### 2 GUIDES

cm	Projection					
	250	300	350	400	450	500
	STD /	STD /	STD /	STD /	STD /	STD /
150	26 /	28 /	30 /	32 / 25	34 / 26	38 / 27
200	30 /	33 /	36 /	38 / 29	41 / 31	46 / 32
250	34 /	38 /	41 /	45 / 34	48 / 35	54 / 37
300	39 /	43 /	47 /	52 / 38	56 / 40	63 / 42
350	43 /	48 /	53 /	58 / 43	63 / 45	73 / 47
400	48 /	54 /	59 /	65 / 47	71 / 50	82 / 52
450	53 /	59 /	66 /	72 / 52	79 / 55	93 / 58
500	58 /	65 /	72 /	79 / 57	86 / 61	103 / 64
550	63 /	71 /	79 /	87 / 62	94 / 66	112 / 70
600	69 /	77 /	85 /	94 / 67	103 / 72	122 / 76
650	74 /	83 /	92 /	102 / 72	111 / 78	/ 82
700	83 /	92 /	102 /	112 / 81	122 / 87	/ 91
750	88 /	99 /	109 /	120 / 86	131 / 93	/ 98

Projection

Width

STD  
Standard

| |  
Added module

P= Minimum inclination for a correct water outflow

### 3 GUIDES

cm	Projection									
	500	550	600	650	700	750	800	850	900	
	STD /	STD /	STD /	STD /	STD /	STD /	STD /	STD /	STD /	
150	27 /	29 /	30 / 25	31 / 26	32 / 27	34 / 27	35 / 28	36 / 29	37 / 30	
200	32 /	34 /	35 / 29	37 / 30	39 / 31	40 / 32	42 / 33	44 / 34	45 / 35	
250	37 /	39 /	41 / 33	43 / 35	45 / 36	47 / 37	49 / 38	51 / 39	53 / 41	
300	42 /	45 /	47 / 38	49 / 39	52 / 41	54 / 42	56 / 43	59 / 45	61 / 46	
350	47 /	50 /	53 / 42	56 / 44	58 / 45	61 / 47	64 / 49	67 / 51	70 / 52	
400	53 /	56 /	59 / 47	62 / 49	65 / 51	68 / 52	72 / 54	75 / 56	78 / 58	
450	58 /	62 /	65 / 51	69 / 54	72 / 56	76 / 58	79 / 60	83 / 62	86 / 65	
500	64 /	68 /	72 / 56	76 / 59	79 / 61	83 / 63	87 / 66	91 / 68	95 / 71	
550	70 /	74 /	78 / 61	82 / 64	87 / 66	91 / 69	95 / 72	99 / 75	103 / 77	
600	76 /	80 /	85 / 66	89 / 69	94 / 72	98 / 75	103 / 78	108 / 81	112 / 84	
650	82 /	87 /	92 / 71	97 / 74	101 / 78	106 / 81	111 / 84	116 / 88	121 / 91	
700	91 /	97 /	102 / 80	107 / 83	112 / 87	117 / 90	122 / 94	125 / 97	133 / 101	
750	98 /	103 /	109 / 85	114 / 89	120 / 93	125 / 96	131 / 100	136 / 104	142 / 108	

### 4 GUIDES

cm	Projection								
	950	1000	1050	1100	1150	1200	1250	1300	
	STD /	STD /	STD /	STD /	STD /	STD /	STD /	STD /	
150	30 / 27	31 / 27	31 / 28	32 / 28	33 / 29	34 / 29	35 / 30	35 / 31	
200	35 / 31	36 / 32	37 / 33	39 / 33	40 / 34	41 / 35	42 / 36	43 / 36	
250	41 / 36	42 / 37	44 / 38	45 / 39	46 / 40	48 / 41	49 / 42	50 / 42	
300	47 / 40	49 / 42	50 / 43	52 / 44	53 / 45	55 / 46	56 / 48	58 / 49	
350	53 / 45	55 / 47	57 / 48	59 / 50	60 / 51	62 / 52	64 / 54	66 / 55	
400	59 / 50	61 / 52	63 / 54	65 / 55	68 / 57	70 / 58	72 / 60	74 / 62	
450	66 / 56	68 / 57	70 / 59	73 / 61	75 / 63	77 / 65	80 / 67	82 / 68	
500	72 / 61	75 / 63	77 / 65	80 / 67	82 / 69	85 / 71	88 / 73	90 / 75	
550	79 / 66	82 / 69	84 / 71	87 / 73	90 / 76	93 / 78	96 / 80	99 / 83	
600	85 / 72	89 / 74	92 / 77	95 / 79	98 / 82	101 / 85	104 / 87	108 / 90	
650	92 / 77	96 / 80	99 / 83	103 / 86	106 / 89	109 / 92	113 / 94	116 / 97	
700	102 / 86	106 / 89	110 / 92	113 / 96	117 / 99	121 / 102	125 / 105	128 / 108	
750	110 / 92	114 / 96	118 / 99	121 / 102	125 / 106	129 / 109	133 / 112	137 / 116	







The KE painting process includes high quality standards, with an 8-stage pre-treatment that includes degreasing, deoxidation, and protective treatments before painting. Thanks to this last phase, components and profiles are further guaranteed against particularly severe environmental situations. At the end of the process the profiles and components are painted with polyester resin-based epoxy powders.

Treated components are periodically tested in salt spray according to the ISO 9227 standard to confirm conformity and consistency of the process.

The European product standard EN 13561: 2015 defines corrosion resistance classes of the metal parts that make up the product according to the table below.

Tests performed on the painted components and profiles allow us to classify the product in the maximum class achievable according to EN 13561: 2015, C2 / 4 (48 h - internal components, 240 h - external components).

Equipped with the most modern process control systems including continuous monitoring in which the working parameters are recorded and corrected every 2 minutes, the new painting process guarantees the high quality characteristics of the product while minimizing the risk of environmental pollution.

This is a choice born from the desire to always keep up with technology while guaranteeing operator safety and low environmental impact.

Thanks to nanotechnologies, the implemented coating constitutes an excellent base for anchoring paints, ensuring excellent adhesion and resisting corrosion.

The plant in which aluminum or galvanized steel products with a length of up to 7 meters can be treated, includes 7 treatment tanks, 1 double compartment drying oven, 1 polymerization oven and 1 purification plant for waste water treatment.

The real focus of the plant, however, is the two powder coating booths, each with 4 stations for manual retouching. The booths allow greater production continuity, thanks to a drastic reduction in required stops for color changes.

### CORROSION RESISTANCE

Classes	1	2	3	4
Internal components	24	48		
External components		48	96	240



When working with color, we know that our whole world is defined by light. And color is nothing more than a breakdown of light. Objects reflect back to our eyes only the color that defines it. This is why it is so important to recognize the close link between color and matter. For this project, there are three keywords that guide the research: Words, Places, Matters.

**WORDS:** Naming colors is important to make them familiar and easily recognizable.

**PLACES:** Places define colors. Recognizing different types of places is a starting point for defining and suggesting color combinations.

**MATERIALS:** Objects do not exist in isolation, but rather match the environment around them: analyzing the materials that make up the environment itself helps us to make decisions; to decide, for example, if the character of a place is false or if instead it is genuinely artistic.

COLOURS RAL



● Ral standard (senza supplemento)



There is increasing demand for high-performance buildings that have a very low energy consumption and use energy derived from renewable sources. In particular, the limitation of solar heat gain is one of the most important aspects of summer thermal comfort. Solar shading plays an essential role in this concept. The gtot value determines the ability of the solar shield to maintain, in an environment directly exposed to solar radiation, a more comfortable temperature than that which would occur with the presence of glass alone. The solar heat gains are directly proportional to the total transmittance of solar energy gtot, a value that depends on the glazing and external shielding. The European product standard EN 13561: 2015 and the EN 14501 standard identify 5 energy performance classes as shown in the table below.

Effect of GTOT on thermal comfort					
Gtot value	$\geq 0,50$	$\geq 0,35 \text{ e } < 0,50$	$\geq 0,15 \text{ e } < 0,35$	$\geq 0,10 \text{ e } < 0,15$	$< 0,10$
Class	0	1	2	3	4
	very mild effect	Mild effect	Moderate effect	good effect	very good effect

Each KE product has a Gtot value according to the shading fabric / profiles used. For details, refer to the information provided with the technical data sheet of the fabric and the CE label.



Vertika is a vertical closure that provides protection from sun and rain.  
It can be equipped with WIND BLOCK, a locking tensioning system for the fabric.  
With Vertika you can use blackout and filtering fabrics to better manage solar radiation.

- AVAILABLE:

110 GPR  
110 GPZ



### Technical Details

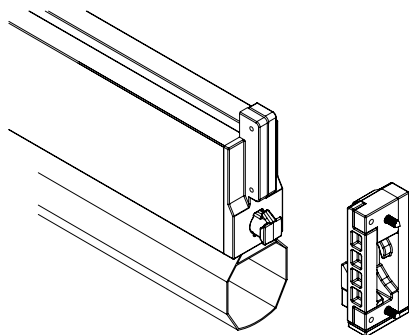

WIND BLOCK: Front bar Interlock device to be used on 100 and 130 Screeny GPZ guide, GPZ I and Gpz Unica. In wind, front bar stays locked in the low position and fabric is steadily tightened when the awning is opened completely.

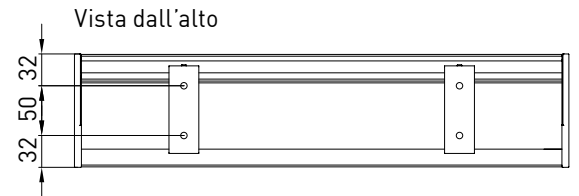
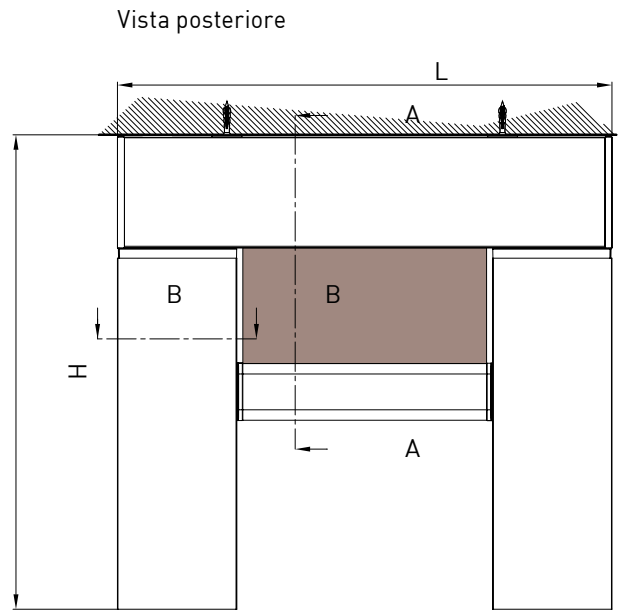
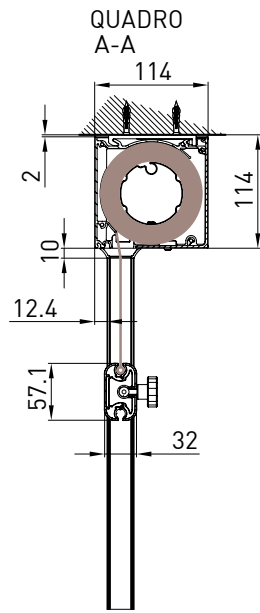
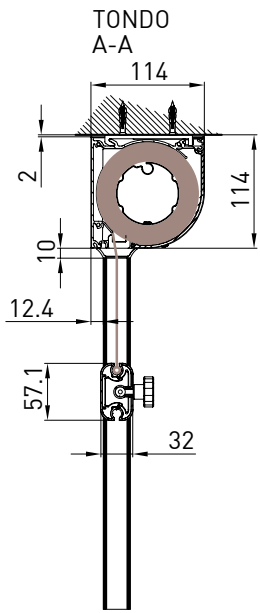

Guida a nicchia  
B-B

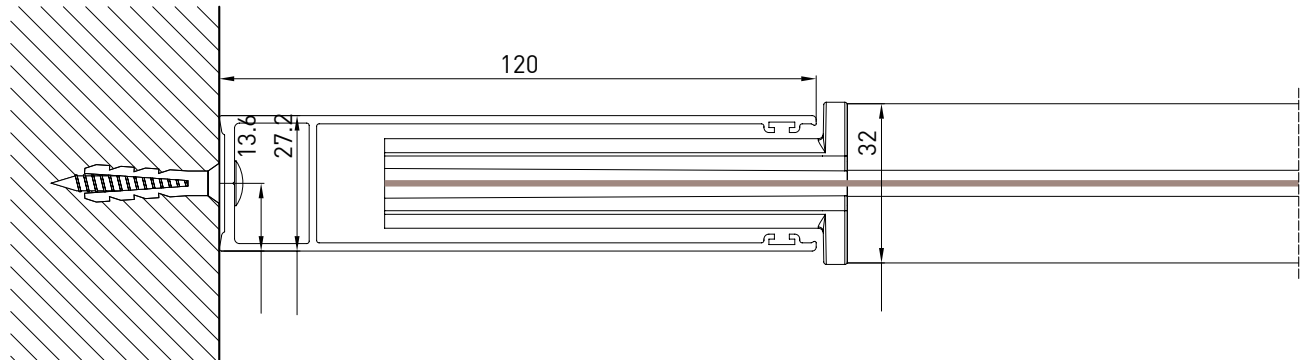

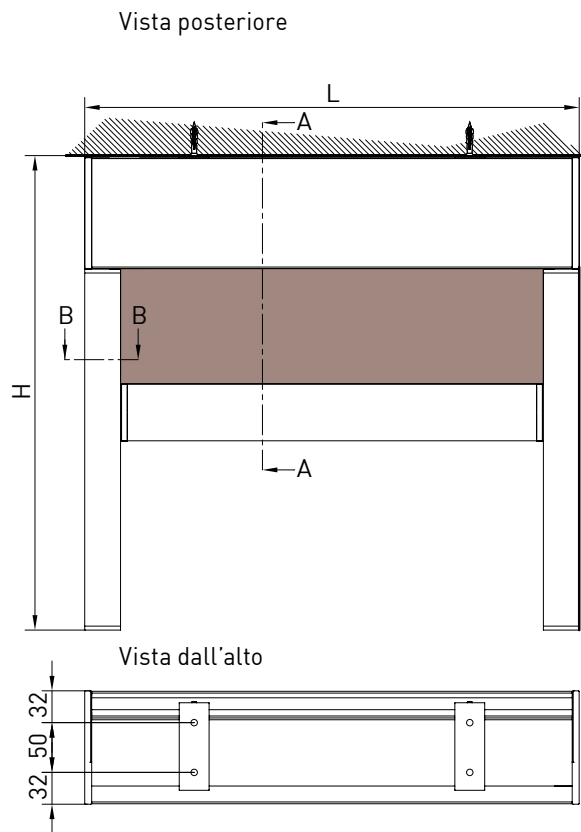
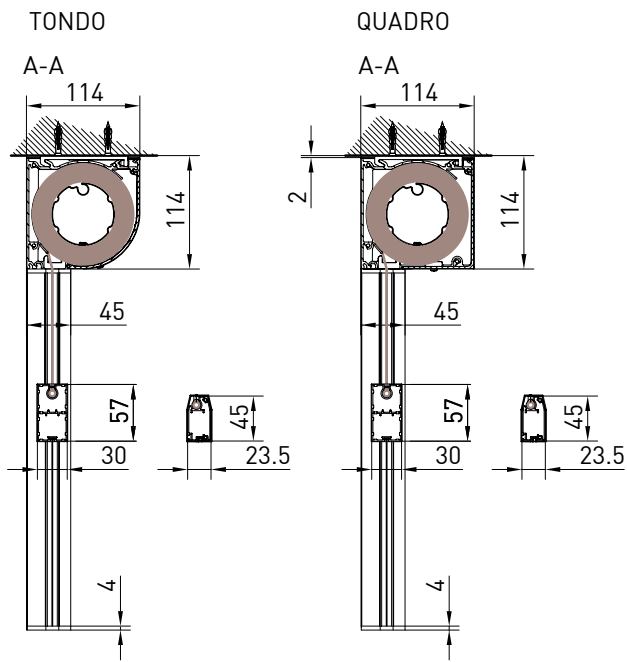

AUTOPORTANTE- QUADRO

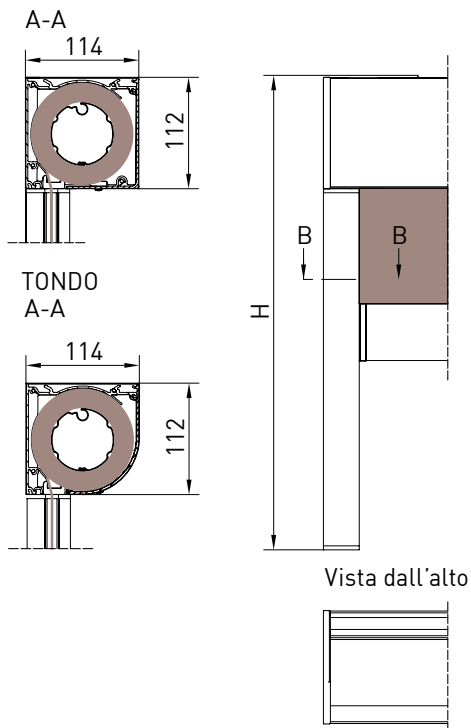

# VERTIKA\_110 GPZ

Guida a nicchia  
B-B

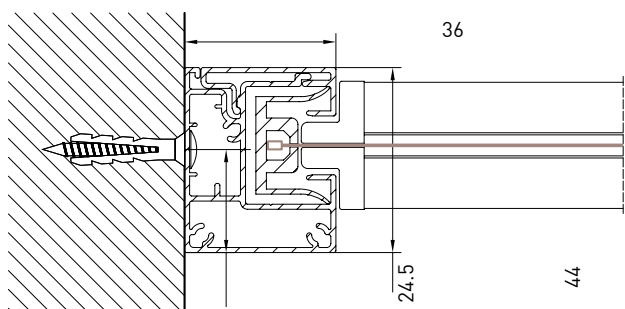

## VERSIONE GPZ C

Guida a nicchia  
B-B

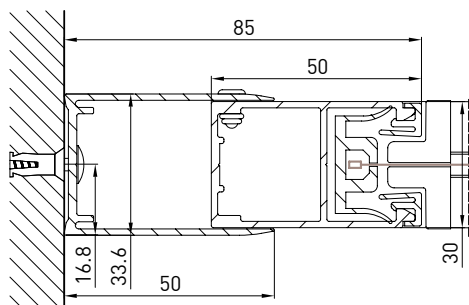

Guida a nicchia  
B-B

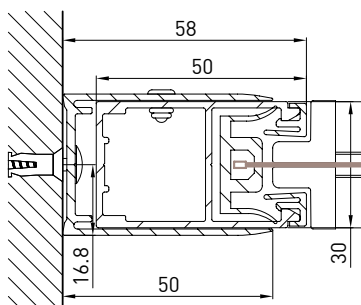

## VERSIONE GPZ I

Guida a nicchia  
B-B

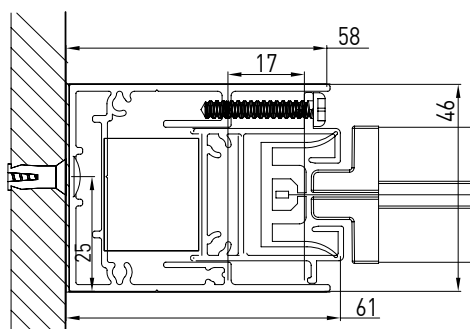

Guida a nicchia  
B-B

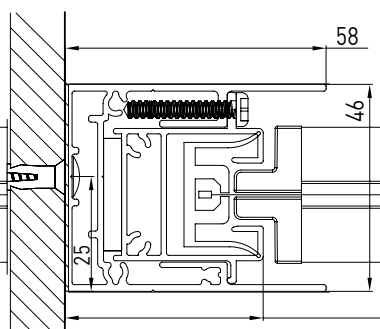

## OPTIONAL SIDE CLOSURES \_ DOORS AND CURTAINS



The doors have been designed to provide protection from water and wind. They are made from extruded aluminum alloy profiles (EN-AW 6060-T6) and 4 + 4 pvd 0.76 safety and shatterproof laminated glass in accordance with UNI 7697 2014. Doors are available in either one or two door versions.

The interior of the structure can be enhanced with decorative curtains. That extra romantic touch which will surely be appreciated by anyone looking for a little privacy or who want "a room all to themselves".



## SPECIAL STRUCTURES

The technical office is available for assistance with non-standard structures such as some examples shown below. KE can also produce special brackets on request.

Cantilevered

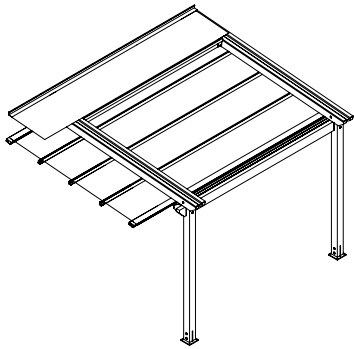

Cantilevered with recess

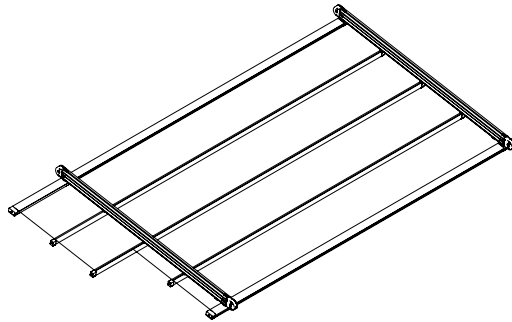

Cantilevered with recess

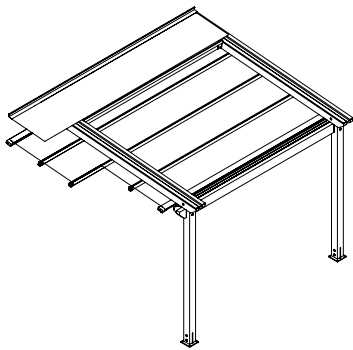

Slanting

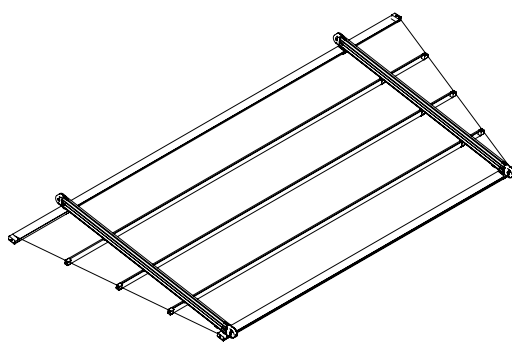

Slanting

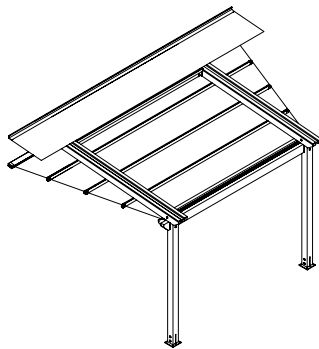

Cantilevered

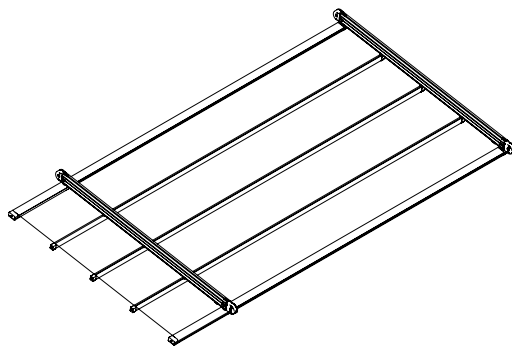

## FABRICS



Thermal comfort blends perfectly with beautiful style thanks to the more than 500 high performance fabrics available. A wide variety of colors, styles and solar shading factors allow for a system that meets your specific needs. All fabrics are CE Certified according to the EN 13561 and EN 14501 technical standards.

N.B.  
See the Fabric Guide for further fabric specifications.

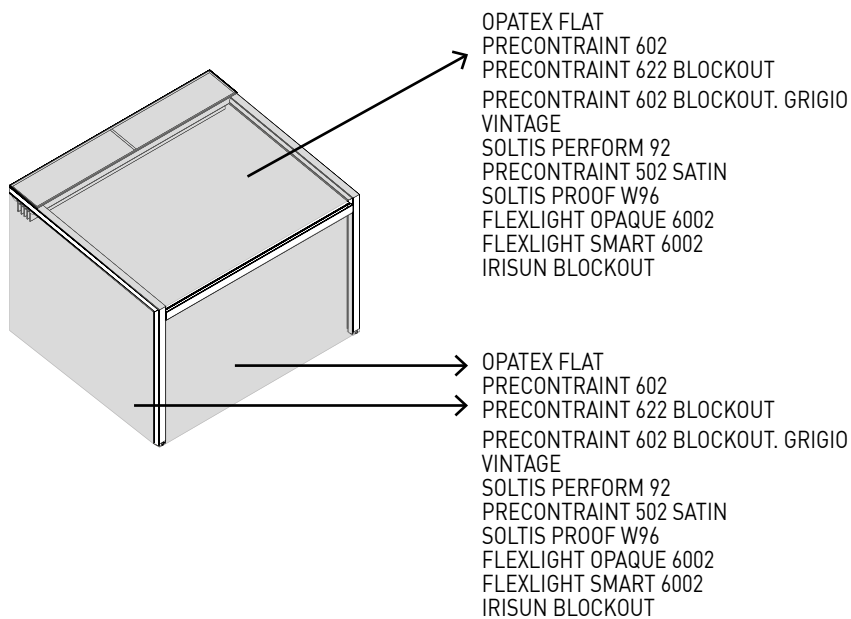

### Standard

---

- OPATEX FLAT

### Optional

---

PRECONSTRAINT 602  
PRECONSTRAINT 622 OSCURANTE  
PRECONSTRAINT 602 OSCUR. GRIGIO  
VINTAGE  
SOLTIS PERFORM 92  
PRECONSTRAINT 502 SATIN  
SOLTIS PROOF W96  
FLEXLIGHT OPAQUE 6002  
FLEXLIGHT SMART 6002  
IRISUN BLOCKOUT

Codice di identificazione del prodotto: GENNIUS A100 STAR – versione con colonna 110 x 110 mm  
 Uso previsto del prodotto: Impiego esterno in edifici e altre costruzioni  
 Nome e indirizzo del fabbricante: KE PROTEZIONI SOLARI S.r.l., Via Calnova 160/a, Noventa di Piave (VE) – Italia  
 Sistema di valutazione e verifica della costanza di prestazione: 4

Classificazione secondo Prospetto 1 - §4.1 EN 13561:2015:

Classi di resistenza al vento	0	1	2	3	4	5	6
Pressione di sicurezza del vento $p_s$ (N/m <sup>2</sup> )	<48	48	84	132	204	324	480
Velocità massima del vento [km/h]	<25	25	35	45	55	70	90

Prestazione dichiarata:

Resistenza ai carichi da vento – Configurazione a 2 guide							
		Larghezza (cm)					
		250	300	350	400	450	500
Sporgenza (cm)	250	6	6	6	6	6	6
	300	6	6	6	6	6	6
	350	6	6	6	6	6	6
	400	6	6	6	6	6	6
	450	6	6	6	6	6	5
	500	6	6	6	5	5	5
	550	6	6	5	5	5	4
	600	6	5	5	4	4	4

Resistenza ai carichi da vento – Configurazione a 3 guide										
		Larghezza (cm)								
		500	550	600	650	700	750	800	850	900
Sporgenza (cm)	250	6	6	6	6	6	6	6	6	6
	300	6	6	6	6	6	6	6	6	6
	350	6	6	6	6	6	6	5	5	5
	400	6	6	6	5	5	5	5	5	4
	450	5	5	5	5	4	4	4	4	4
	500	5	5	4	4	4	4	4	4	3
	550	4	4	4	4	4	-	-	-	-

Resistenza ai carichi da vento – Configurazione a 4 guide										
		Larghezza (cm)								
		950	1000	1050	1100	1150	1200	1250	1300	
Sporgenza (cm)	250	6	6	6	6	6	6	6	6	
	300	6	6	6	6	6	6	6	6	
	350	6	6	6	6	6	5	5	5	
	400	5	5	5	5	5	5	5	5	
	450	5	5	4	4	4	4	4	4	
	500	4	4	4	4	4	4	4	3	
	550	4	4	4	3	3	-	-	-	

Trasmittanza totale di energia solare  $g_{tot}$ : fare riferimento al valore riportato in etichetta CE in base al tipo di tessuto utilizzato. La fornitura dei prodotti sopra indicati è conforme all'insieme delle prestazioni dichiarate. Si rilascia la presente dichiarazione di prestazione in conformità al regolamento (UE) n.305/2011 sotto la responsabilità esclusiva del fabbricante sopra identificato.



EN 13561:2015

Noventa di Piave, 15 Febbraio 2023

KE PROTEZIONI SOLARI S.r.l.  
 Simone Mazzon  
 Amministratore delegato



Lighting plays a very important role in allowing our pergolas to be used at any time of day. KE uses LED lights, perfectly integrated into the profiles of the structures. LED technology allows for low energy consumption, multiple applications and changes to light color and intensity using a simple remote control.

N.B.  
See the Fabric Guide for further fabric specifications.



DATI\_TECNICI:

STRIP LED	
<b>Watt</b>	10W
<b>volt</b>	24V
<b>flow</b>	830lm
<b>Color temperature</b>	3400 K
<b>LED/m</b>	98 led/m



### **EN ISO 9001**

KE has adopted a Quality Management System compliant with EN ISO 9001 requirements in order to maintain and increase quality and meet the highest customer expectations. This continuous improvement, through the control of all processes and careful evaluation of risks and opportunities, engages the entire organization in the development of systems to ensure the safety and reliability of the product and in the search for innovative solutions and technologies.

### **OHSAS 18001**

KE has activated a Safety Management System as an integral part of its work organization, committing itself to organizing the entire structure in order to pursue the objectives of continuous improvement in terms of safety and health protection. Training, knowledge and compliance with current legislation on health and safety at work, cooperation and collaboration and preventive activities are actively pursued in order to minimize the possibility of non-compliance.

### **EN ISO 14001**

KE is ISO 14001 certified for environmental management and strives to be an example of respect for environmental resources and for the continuous improvement of its environmental management system. It is committed to continuous improvement and pollution prevention in compliance with applicable laws, regulations and standards; systematically detects any environmental impact of manufacturing processes, promotes the culture of recovery and recycling in the company and in the related production chain.

### **CE MARK \_ EN 13561**

The CE marking of outdoor awnings is a signal to the Consumer that the product can be sold freely in the EU single market, as it complies with Community provisions which recognize safety as the priority of every product that has this agreed upon reference standard. Verification of wind resistance capacity and the clear indication of the ability of the awning to contribute to the energy savings of the building (Gtot), are some of the commitments that the manufacturer makes to a product that has earned the CE marking. The name of the manufacturer, the reference standard (in our case EN 13561) accompany a product that is properly adapted to European indications.

### **CE MARK \_ EN 1090-1**

KE extended the CE marking in 2015 to stationary awnings, which are among the aluminum structural components covered by the international standard EN 1090-1. This marking reflects our use of rigorous structural design and manufacturing with qualified processes, adequate industrial resources and qualified personnel.



KE si è adattata alle nuove modalità di fruizione del prodotto lavorando a uno showroom digitale che è in grado di regalare all'utente un'esperienza visiva di forte impatto, uno spazio funzionale dove muoversi liberamente, ricevere informazioni dettagliate sui prodotti con un semplice clic, accedere in maniera veloce e intuitiva ai contenuti di interesse. Sono presenti contenuti visualizzabili come la realtà aumentata e file scaricabili come schede tecniche, brochure e modelli 3D.



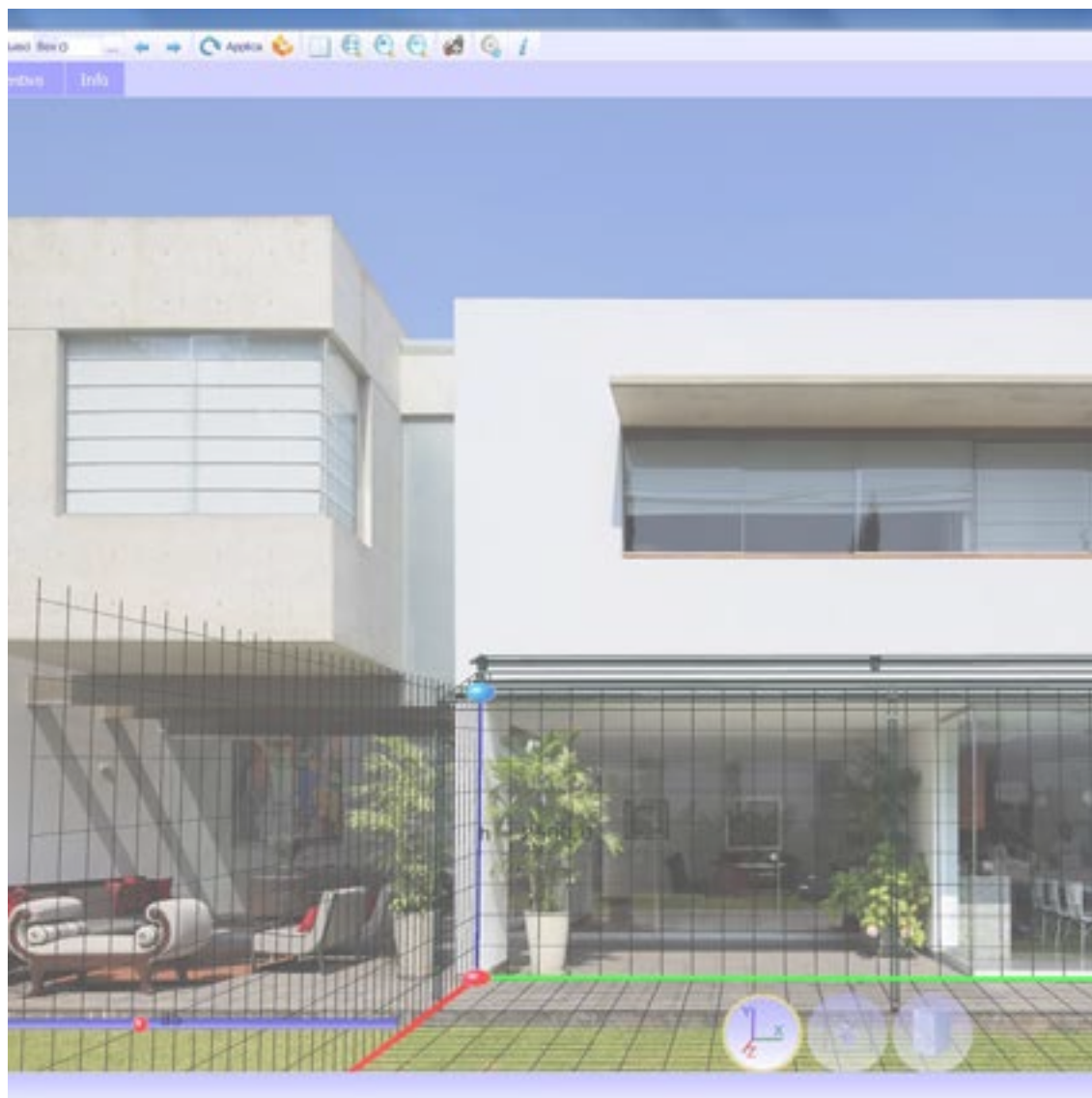

Il sistema ordini B2B KE è un servizio semplice e intuitivo per effettuare gli ordini comodamente online. Una grafica accattivante, numerose funzionalità ed una modalità di utilizzo facile e intuitiva che permette di accedere in tempo reale a tutte le informazioni relative allo storico degli ordini e al processamento di quelli attuali. Con il Configuratore 3D Cad Lite è invece possibile configurare i modelli Genius e Bioclimatica grazie ad un catalogo online costantemente aggiornato. Grazie ad un'interfaccia facile da utilizzare, consente inoltre di formulare un preventivo completo riducendo al minimo l'errore.

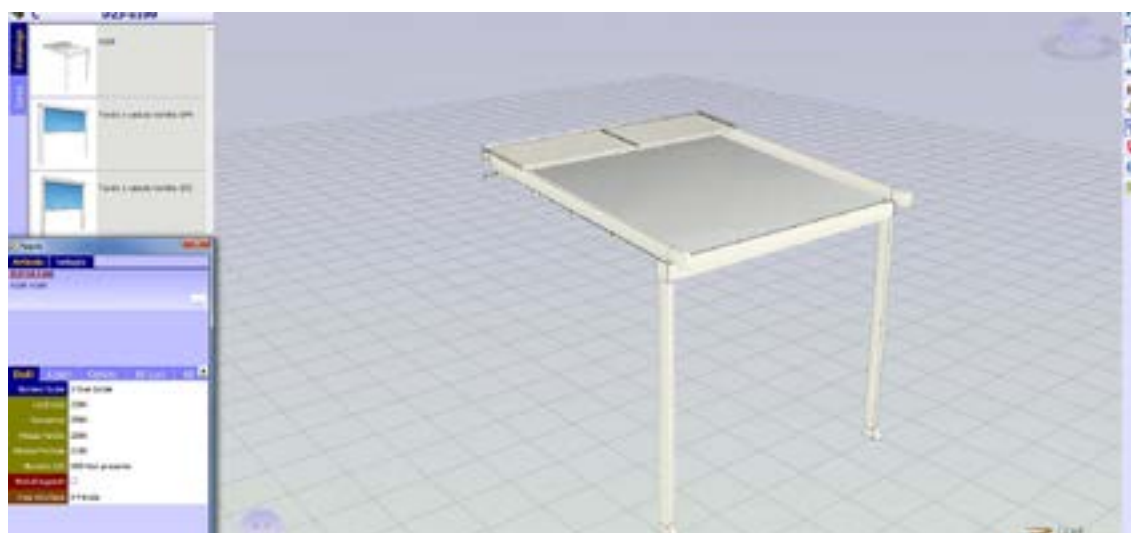

Home > Ambienti

## Ambienti

La nostra missione è creare nuovi spazi outdoor da vivere in totale armonia. Grazie alle nostre coperture solari e alle strutture per esterni personalizzate, potrai arredare con stile il tuo terrazzo, giardino, attico, ma anche modulare. [Leggi di più](#)

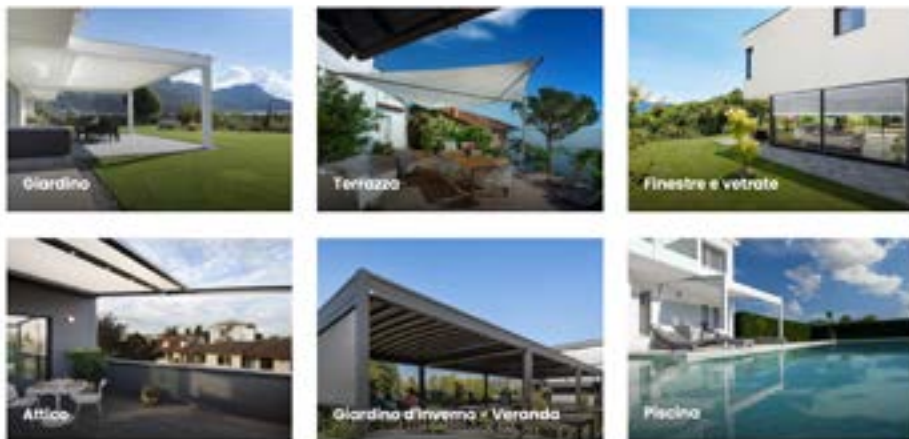

La tecnologia BIM migliora il metodo di lavoro dei progettisti e ad oggi rappresenta la principale fonte di informazione per la realizzazione di un progetto. Con il BIM il modello è generato in un "3D parametrico" da cui possono discendere automaticamente una serie di informazioni come viste 2D, prospetti, sezioni ma anche computi metrici e molto altro. All'interno del sito KE è possibile trovare la galleria BIM dei principali modelli KE, le certificazioni e tutta la documentazione tecnica utile per ciascun prodotto: [www.keoutdoordesign.com](http://www.keoutdoordesign.com)





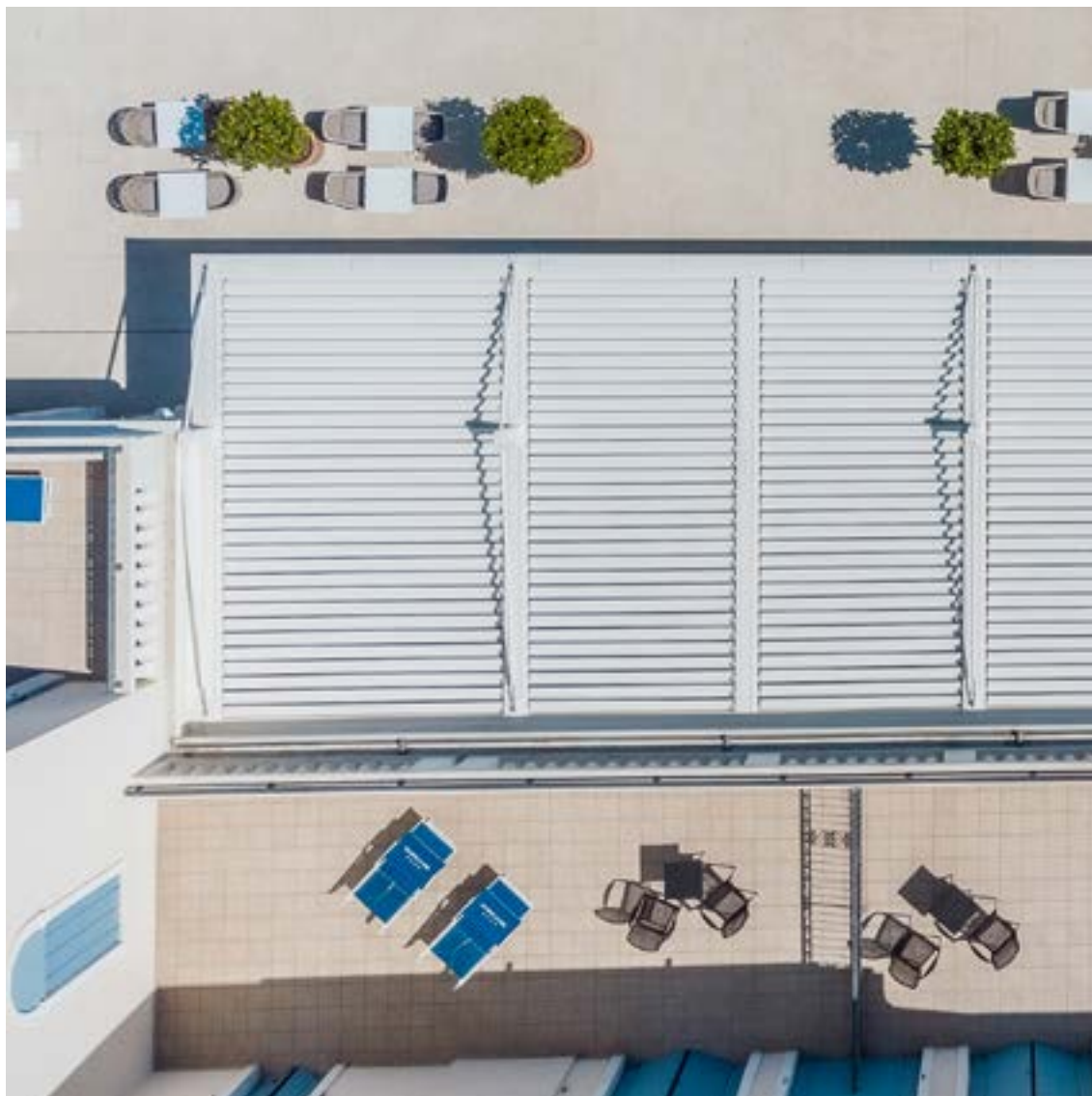

**UN GRUPPO,  
UNA VISIONE,  
UN GRUPPO IN EVOLUZIONE**

Dal 1987 KE progetta e produce tende a bracci, a cassonetto, a caduta, cappottine, pensiline ed è specializzata in strutture ombreggianti che valorizzano la vivibilità dell'outdoor, fino ad arrivare alla riprogettazione e il restyling dell'arredo urbano. Sia per la varietà di gamma che per la profondità delle configurazioni, KE è una realtà manifatturiera in grado di soddisfare le richieste più esigenti di designer, architetti, serramentisti, tappezzieri e professionisti dell'outdoor.



**Migliorare l'esperienza**

Grazie alla professionalità e all'esperienza di KE potrai affidarti a prodotti di qualità studiati per migliorare l'esperienza outdoor dei tuoi clienti. Con KE sarà più facile vivere lo spazio esterno in perfetta sintonia con l'ambiente circostante, ampliando i punti di vista e garantendo il massimo comfort in tutte le stagioni.