

RAL STANDARD

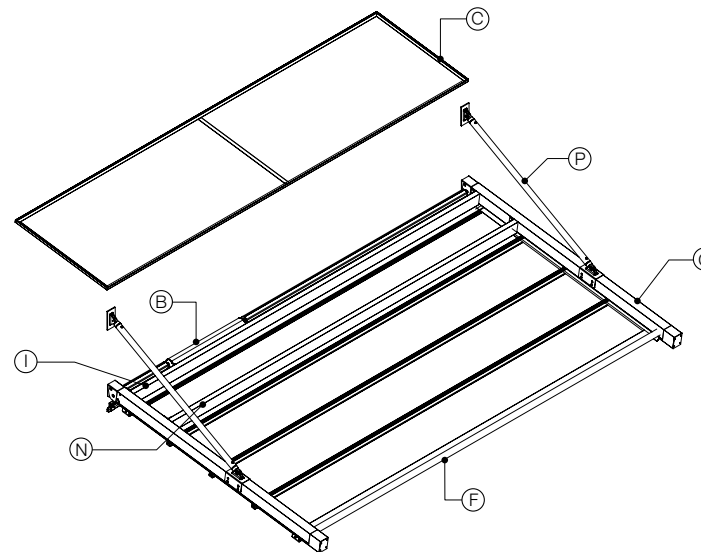

9010 WHITE



TESSUTI - FABRICS €/mq

TESSUTI - FABRICS	€/mq
PRECONTRAIT 602	
PRECONTRAIT 622 OSCURANTE	
PRECONTRAIT 622 OSCUR. GRIGIO	+ 15,00
VINTAGE	+ 16,00
SOLTIS PERFORM 92	+ 34,00
PRECONTRAIT 502 SATIN	+ 19,00
SOLTIS PROOF W96	+ 57,00
FLEXLIGHT OPAQUE 6002	+ 14,00
FLEXLIGHT SMART 6002	+ 12,00
IRISUN BLOCKOUT	+ 57,00

OPTIONAL

OPTIONAL

MUSICA
MUSICLUCI
LIGHT

 Struttura a pensilina in alluminio con tenda richiudibile ad impacchettamento formata da un telo fissato ad un sistema di traversi e guide che ne permettono lo scorrimento orizzontale. La struttura poggia su due staffe laterali che fungono da spinta e stabilizzano la struttura stessa. Resistenza al vento garantita fino alla classe 6 secondo la EN 13561.

La formazione di condensa sul telo non è da considerarsi difetto, si tratta di un fenomeno naturale.

Verificare la tenuta della parete per l'installazione della struttura utilizzando la tabella di carico dei tasselli presente nel manuale d'installazione.

- C Tettuccio copritenda
- B Comando di movimentazione elettrico
- I Traversa supporto motore
- O Guida di scorrimento
- F Profilo frontale
- N Traversa supporto tettuccio
- P Tirante

 Aluminum canopy structure, with packaging retractable awning, consisting in a fabric fixed to a crossbars and guides system, that allows the horizontal sliding. The structure rests on two small but very strong side brackets of an attractive design.

Guaranteed wind resistance up to class 6 according to EN 13561.

The development of condensation on the fabric is natural and not to be considered as a defect. Check the wall resistance for the installation of the structure using the blocks loading table available in the installation manual.

- C Protection hood
- B Moving electrical control
- I Supporting motor crossbar profile
- O Sliding guide
- F Frontal girder
- N Supporting hood crossbar profile
- P Tightener

 Vordachstruktur in Aluminium mit einer Markise, bei der sich das Tuch durch einfalten schliesst. Dieses ist in einem System aus Querträgern und Führungsschienen bestehend, sodass ein waagrechtes laufen möglich ist, befestigt. Die Regenstruktur auf zwei kleinen aber widerstandsfähigen seitlichen Konsolen. Windbeständigkeit: nach EN 13561 bis Klasse 6 garantiert.

Die Entwicklung von Kondensation auf den Stoff ist nicht ein Defekt, sondern ist natürlich.

Vor der Montage prüfen Sie immer die Mauer, ob sie dem Gewicht standhaelt. Die Tabellen mit den dazugehörigen Dübeln, sehen Sie im Installationshandbuch.

- C Schutzdach der Markise
- B Elektrische Bedienung
- I Querträgerbalken für den Motor
- O Laufschiene
- F Frontbalken
- N Querträgerbalken für das Schutzdach
- P Spannteil

 Structure auvents en aluminium avec store rétractable par emballage formé par une toile fixée à un système de traverses et glissières qui permettent le glissement horizontal. La structure est fixée sur deux petits mais résistants supports latéraux. Résistance au vent garantie jusqu'à la classe 6 selon EN 13561.

Le développement de condensation sur le tissu n'est pas considéré un défaut, c'est un phénomène naturel.

Contrôler la résistance du mur pour l'installation de la structure en utilisant le tableau de valeur de charge du matériel d'ancrage préconisé, présent dans notre manuel d'installation.

- C Auvent de protection
- B Commande pour le manoeuvre électrique
- I Profil de traverse support moteur
- O Glissière pour le glissement
- F Poutre frontale
- N Profil de traverse support auvent
- P Tirant

 Estructura a marquesina de aluminio con toldo que se puede empaquear hecha por un tejido fijado a un sistema de perfiles transversales y guías que permiten el escurrimiento horizontal. La estructura es fijada sobre dos pequeños pero resistentes soportes laterales, en design cautivador.

Resistencia al viento garantizada hasta la clase 6 según la EN 13561.

La formación de agua de condensación no es un defecto sino un fenómeno natural.

Verificar el estado de la pared para instalaciones de la estructura utilizando la tabla de carga de los tacos presente en el manual de instalación.

- C Tejadillo cubretoldo
- B Mando de movimiento eléctrico
- I Perfil transversal soporte motor
- O Guía de desplazamiento
- F Viga frontal
- N Perfil transversal soporte tejadillo
- P Tensor



Schema tecnico generale/General technical plan/Allgemein-technisches Schema/Plan technique général/Dibujo tecnico general

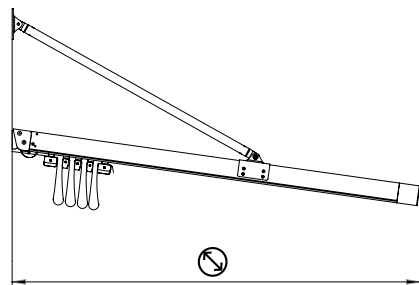

Larghezza interasse guide/Guides interaxis width/Breite des Achsabstandes der Führungsschienen/Largeur entraxe coulisses/Linea guía intereje

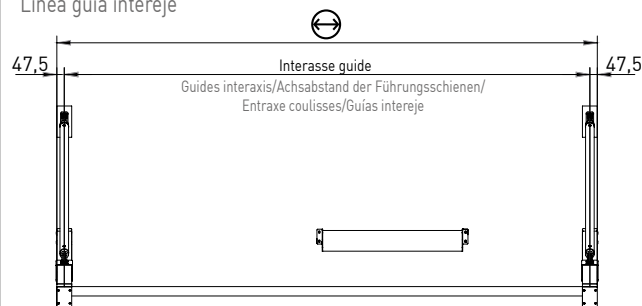

Dimensioni profili/Profiles dimensions/Profilabmessungen/Mesures profils/Dimensiones perfiles

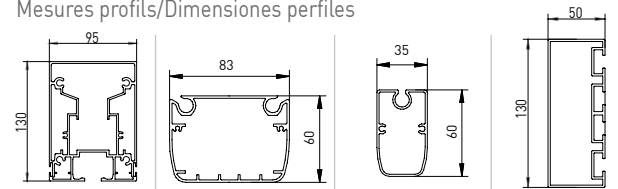

Guida Guide Führungsschiene Glissière Guía	Terminale Terminal bar profile Fallstange Barre de charge Terminal	Traverso Porta Tessuto Fabric carrying Crossbar profile Stoffquerträger Profil de traverse porte tissu Palillo	Profilo supporto guida Guide support profile Tragprofil für Führungsschiene Profil support coulisse Perfil soporte guía
--	--	---	--



Applicazione a parete/Wall installation/Wandmontage
Pose au mur/Instalación a pared

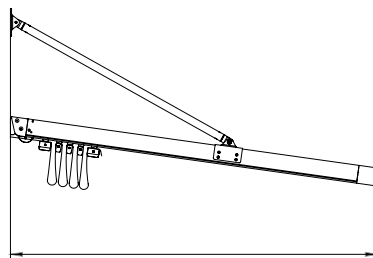

Applicazione lato guida/Application slide side/Anwendung Seitenführungsschiene/Application cote glissiere/Instalación lado guía

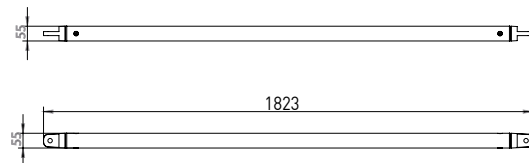
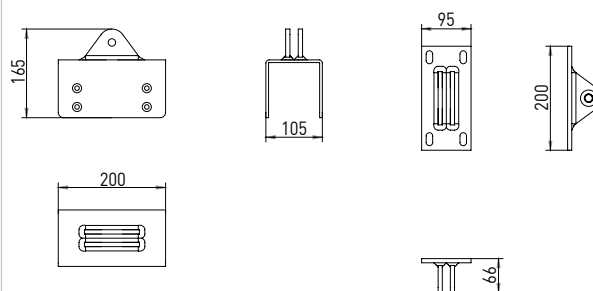

Per tabelle pendenze vedi pag.17 - For slope tables please see page 17 - Für Neigungstabellen siehe S. 17 - Pour les tableaux des différences de niveau, voir p. 17 - Para las tablas de inclinación véase pág. 17

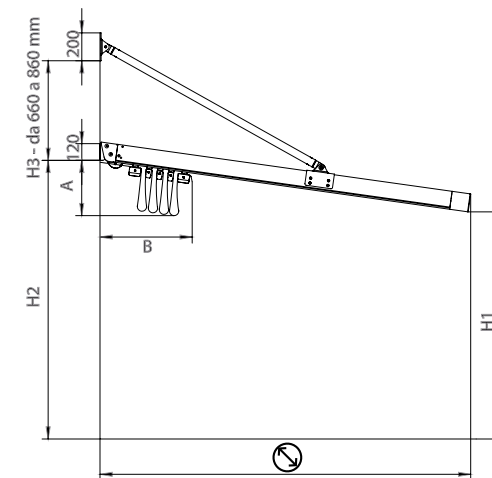

Valori indicativi degli ingombri del telo e del numero di traversi portatelo.

Attenzione: i valori esposti possono variare a seconda della pendenza.

Indicative values of the fabric encumbrance and the number of the fabric carrying crossbar profiles. Attention: the indicated values may change according to the inclination.

Richtwerte der Ausmaße des Tuches und der Anzahl der Stoffquerträger Achtung: die angegebenen Werte können sich je nach Gefälle ändern.

Valeurs indicatives des encombrements de la toile et du nombre de profils de traverse porte tissu. Attention: les valeurs peuvent changer selon la pente

Valores indicativos de las dimensiones del tejido y del número de palillos.

Atención: los valores indicados pueden cambiar según la inclinación.

	A cm	B cm	N
250	42	63	5
300	42	63	5
350	43	69	6
400	43	74	7

N Numero traversi (compreso terminali). Misura massima interasse traversi portatelo 58 cm.

N Crossbar profile numbers (terminals included). Maximum interaxis fabric carrying cross bar profiles measure cm 58.

N Anzahl der Querträger (inklusive Fallstangen). Maximaler Achsabstand der Stofftragerschienen cm 58.

N Nombre profils de traverse (compris barres de charge).

Mesure maximale entraxe profils traverse porte tissu cm 58.

N Numero de perfiles transversales (terminales incluidos). Medida máxima intereje perfiles transversales para lona cm 58.