





Struttura a moduli affiancabili.

Modular structure - Struktur mit aneinanderstellbaren Modulen - Possibilité de juxtaposer les modules - Estructuras modulares contiguas



Dimensioni modulo singolo fino ad un massimo di L. 600 cm e SP. 1400 cm.

Single module dimensions up to a maximum of W.600cm and P.1400cm - Dimensione eines einzelnen Moduls max. Breite 600cm und Ausladung 1400cm - Dimensions maximales du module simple Largeur. 600 cm et Avancée. 1400 cm - Dimensiones cada módulo hasta un máximo de L. 600cm y Salida 1400cm



Tre tipologie di copertura (arco, singola falda, doppia falda).

Three types of coverage (arc, single pitch, double pitch) - Drei verschiedene Abdeckungen (Bogen, Giebel oder Vordachförmig) - Trois types de couverture (arc, simple pente, double pente) - Tres tipologías de coberturas (arco, capa simple, doble capa)



Elevata possibilità di personalizzazione.

High possibility of customization - Spezialanfertigungen möglich - Possibilité élevée de personnaliser - Gran posibilidad de personalización



Ottima tenuta ad acqua e vento.

Excellent water and wind resistance - Sehr stabil bei Wasser und Wind - Tenue à l'eau et au vent optimale - Excelente cierre contra el aire y el viento



Carico su copertura: minimo 80kg/mq.

Coverage loading: minimum 80 kg/m² - Traglast auf der Abdeckung: min. 80kg/qm - Charge de la couverture: minimum 80kg/m² - Carga sobre cubierta: mínimo 80kg/mq.



Servizio di misurazione, progettazione ed installazione con personale KE.

Measurement service, design and installation with KE personnel - Abmessung, Projektplanung und Installation von dem KE Personal möglich - Service métrage, projet et installation avec le personnel KE - Servicio de medición, proyecto e instalación con personal KE



Chiusure perimetrali.

Perimetral closures - Schließungen auf der Seite - Fermetures périmétrales - Cerramientos perimetrales



Movimentazione tessuto tramite cinghia dentata.

Fabric movement through a toothed belt - Das Tuch wird mit einem Zahnriemen bewegt - Mouvement de la toile par une sangle crantée - Movimentación del tejido por medio de cinta dentada

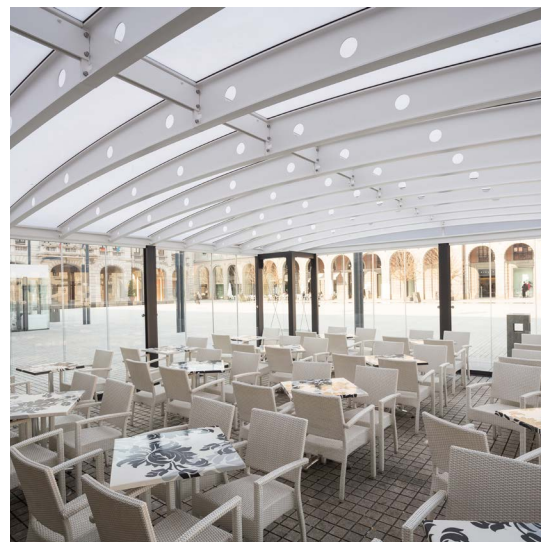

ROOMY

ROOMY fisso ad arco D90



COLORI STANDARD — STANDARD COLORS

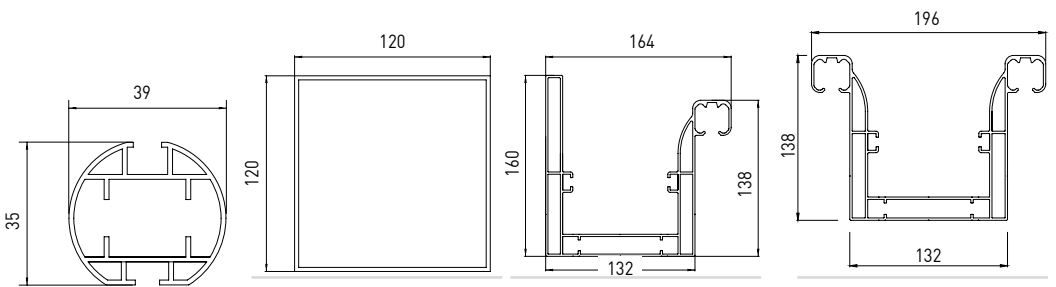
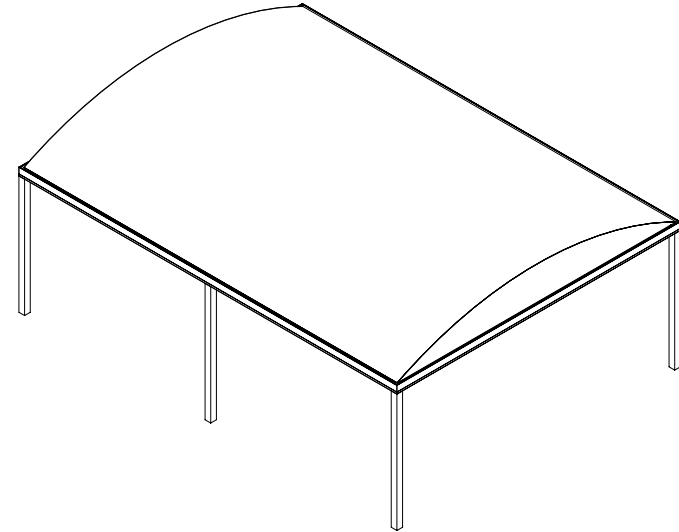
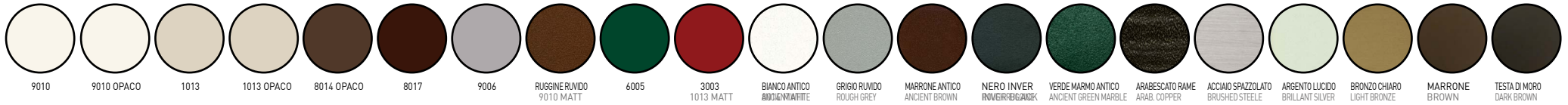

- Profilo arco**
 Arch profile
 Bogenprofil
 Profil colonne
 Perfil de arco
- Profilo colonna**
 Pillar profile
 Pfeilerabdeckprofil
 Profil colonne
 Perfil columna
- Profilo portante grande esterna 39201**
 39201 main external profile
 Grosses Aussenträgerprofil 39201
 Profil portante grand extérieur 39201
 Perfil portante grande externo 39201
- Profilo portante grande centrale 38218**
 38218 main central profile
 Grosses zentrales Trägerprofil 38218
 Profil portante grand central 38218
 Perfil portante grande central 38218

